



Z127-C-E-R

8-5/8" [219] DIAMETER DECK RECEPTOR DRAIN
W/ UNDERDECK CLAMP, STATIC EXTENSION,
AND ROOF SUMP RECEIVER

SPECIFICATION SHEET

TAG _____

Dimensional Data (inches and [mm]) are Subject to Manufacturing Tolerances and Change Without Notice

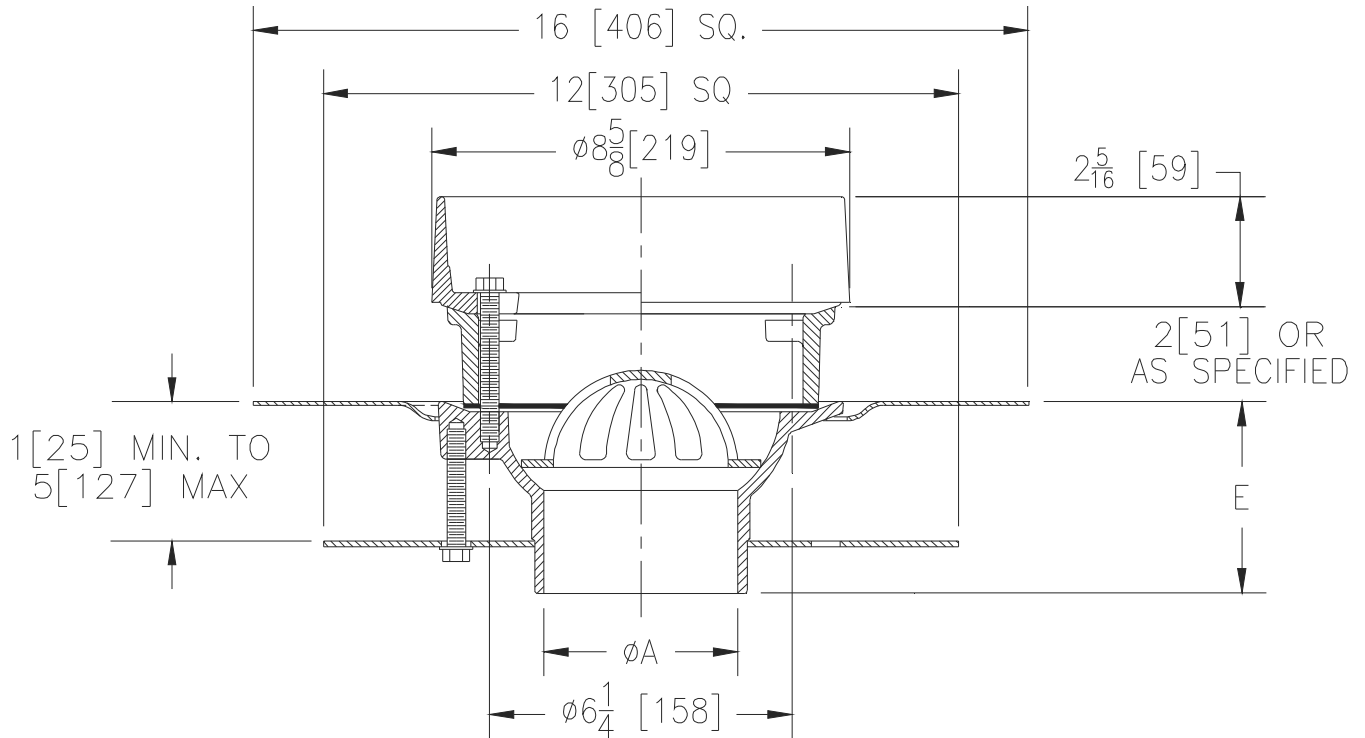

A Pipe Size in [mm]	Approx Wt. lbs [kg]
2,3,4 [51,76,102]	19 [9]

ENGINEERING SPECIFICATION: ZURN Z127-C-E-R

8-5/8" [219mm] Diameter deck receptor drain, Dura-Coated cast iron body with combination membrane flashing clamp/deck receptor frame, static extension, gasket, underdeck clamp, roof sump receiver and internal dome strainer.

OPTIONS (Check/specify appropriate options)

PIPE SIZE

- 2,3,4 [51,76,102]
- 2 [51]
- 3 [76]
- 4 [102]
- 2,3,4 [51,76,102]
- 2,3,4 [51,76,102]

(Specify size/type) OUTLET

- _____ IC Inside Caulk
- _____ IP Threaded
- _____ IP Threaded
- _____ IP Threaded
- _____ NH No-Hub
- _____ NL Neo-Loc

E BODY HT. DIM.

- 3-7/8 [98]
- 2-7/16 [62]
- 2-3/4 [70]
- 3 [76]
- 3-31/32 [101]
- 3-27/32 [98]

PREFIXES

- _____ Z D.C.C.I. Body with Collar*

SUFFIXES

- _____ -AR Acid Resistant Epoxy Coated
- _____ -G Galvanized Cast Iron
- _____ -HD High Dome
- _____ -TC Neo-Loc Test Cap Gasket
(2,3,4 [51,76,102] NL Bottom Outlet Only)

* Regularly furnished unless otherwise specified.