



# Z310-82 THOROFLUSH DRAIN WITH SOLID COVER FOR HEAVY-DUTY FORKLIFT TRAFFIC

SPECIFICATION SHEET

TAG \_\_\_\_\_

Dimensional Data (inches and [ mm ]) are Subject to Manufacturing Tolerances and Change Without Notice

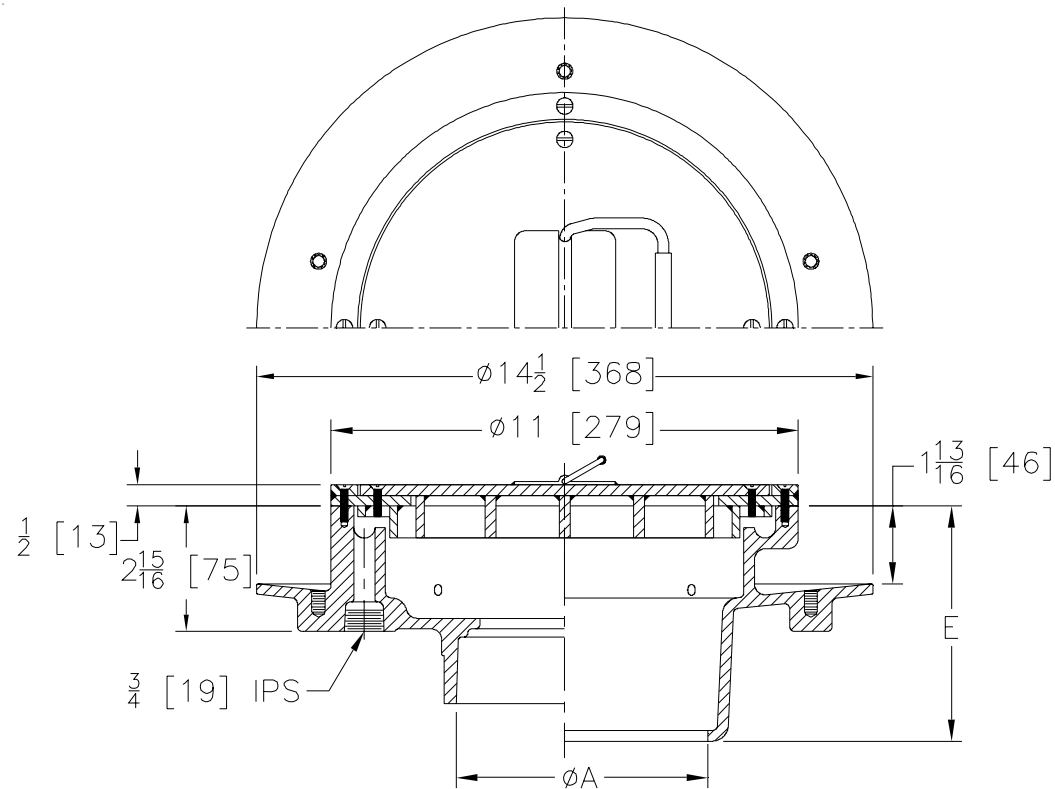

A Pipe Size	Approx. Wt. Lbs. [kg]
2-3-4-6 [51-76-102-152]	28 [13]

**ENGINEERING SPECIFICATION: ZURN ZS310-82**

11 [279] Top Thoroflush Drain, cast iron body with white acid resistant epoxy coated exterior and interior, bottom outlet with seepage pan, stainless steel flushing rim top and, heavy-duty stainless steel cover with lift handle, rated at 10,000 lbs. [4356 kg.] maximum safe live load.

**OPTIONS** (Check/specify appropriate options)

**PIPE SIZE**

- 2-3-4-6 [51-76-102-152]
- 2-3-4-6 [51-76-102-152]
- 2-3-4-6 [51-76-102-152]
- 2-3-4 [51-76-102]

(Specify size/type) **OUTLET**

- \_\_\_ IC Inside Caulk
- \_\_\_ IG Inside Caulk w/Sealtrol Gskt.
- \_\_\_ IP Threaded
- \_\_\_ NL Neo-Loc

**'E' BODY HT. DIM.**

- 5 1/2 [140]
- 5 1/2 [140]
- 5 1/2 [140]
- 4 5/8 [117]

**PREFIXES**

- \_\_\_ ZS Cast Iron Body w/ A.R.C. Interior and Exterior w/ Stainless Steel Cover

**SUFFIXES**

- \_\_\_ -C Clamping Collar
- \_\_\_ -TC Neo-Loc Test Cap Gasket (2 [51]-4 [102] NL Bottom Outlet Only)
- \_\_\_ -VP Vandal-Proof Screws In Frame
- \_\_\_ -WB Water Supply Control Box (See Z1464)

\*REGULARLY FURNISHED UNLESS OTHERWISE SPECIFIED

REV.	DATE: 1/30/08	C.N. NO. 98050
DWG. NO. P-15511 PRODUCT NO. Z310-82		

ZURN INDUSTRIES, LLC ♦ SPECIFICATION DRAINAGE OPERATION ♦ 1801 Pittsburgh Ave. ♦ Erie, PA 16514

Phone: 814/455-0921 ♦ Fax: 814/454-7929 ♦ World Wide Web: www.zurn.com

In Canada: ZURN INDUSTRIES LIMITED ♦ 3544 Nashua Drive ♦ Mississauga, Ontario L4V1L2 ♦ Phone: 905/405-8272 Fax: 905/405-1292