



# Z107-94

## 20 [508] WIDE DECK FLANGE ROOF DRAIN WITH PERFORATED EXTENSION AND STANDPIPE

TAG \_\_\_\_\_

Dimensional Data (inches and [ mm ]) are Subject to Manufacturing Tolerances and Change Without Notice

4 [102] PVC STANDPIPE  
(HEIGHT AS SPECIFIED)

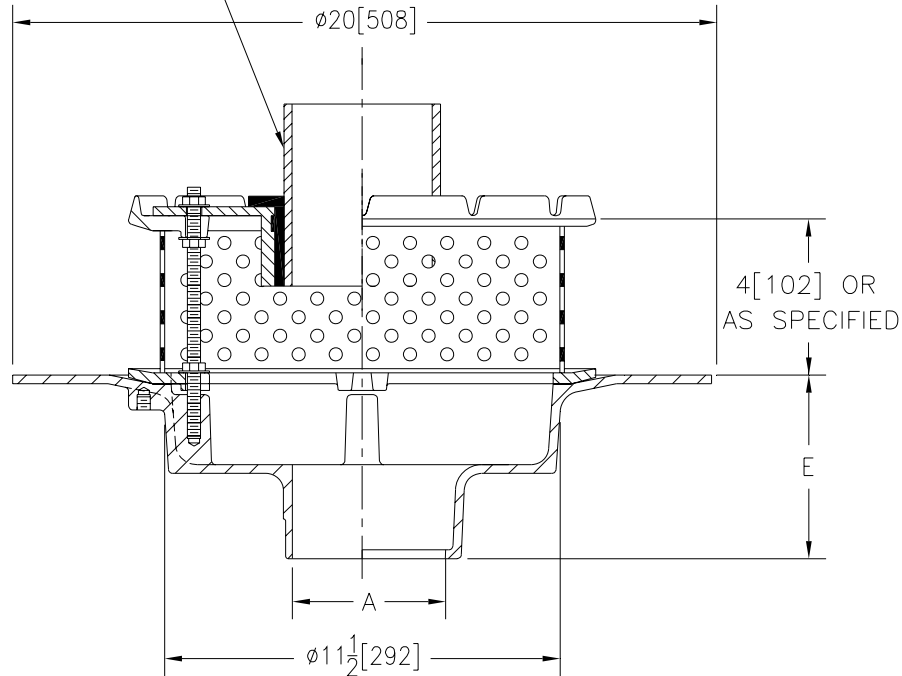

A- Pipe Size In.	Approx. Wt. Lbs. [kg]
3-4[76-102]	41 [19]
6-8[152-203]	

**ENGINEERING SPECIFICATION: ZURN Z107-94**

20 [508] Diameter wide deck flange roof drain. Dura-Coated cast iron with combination membrane flashing clamp/gravel guard, stainless steel perforated extension and 4 [102] PVC standpipe (specify height).

**OPTIONS** (Check/specify appropriate options)

**PIPE SIZE**

- 3,4,6[76,102,152]
- 3,4,6,8[76,102,152,203]

(Specify size/type) **OUTLET**

- \_\_\_\_\_ IC Inside Caulk
- \_\_\_\_\_ NH No-Hub

**E BODY HT. DIM.**

- 5 1/4 [133]
- 5 1/4 [133]

**PREFIXES**

- \_\_\_ Z D.C.C.I. Body\*

**SUFFIXES**

- \_\_\_ -AC Angular Underdeck Clamp
- \_\_\_ -AR Acid Resistant Epoxy Coated Finish
- \_\_\_ -C Underdeck Clamp
- \_\_\_ -G Galvanized Cast Iron
- \_\_\_ -XJ Vertical Expansion Joint (See Z190)
- \_\_\_ -89 2 [51] High External Water Dam

REV.	DATE: 4/10/06	C.N. NO. 95019
DWG. NO. P-15265 PRODUCT NO. Z107-94		

\*REGULARLY FURNISHED UNLESS OTHERWISE SPECIFIED