



Z100-231

15 [381] DIAMETER MAIN ROOF DRAIN W/ PERFORATED STANDPIPE AND STAINLESS STEEL PERFORATED GRAVEL GUARD

SPECIFICATION SHEET

TAG _____

Dimensional Data (inches and [mm]) are Subject to Manufacturing Tolerances and Change Without Notice

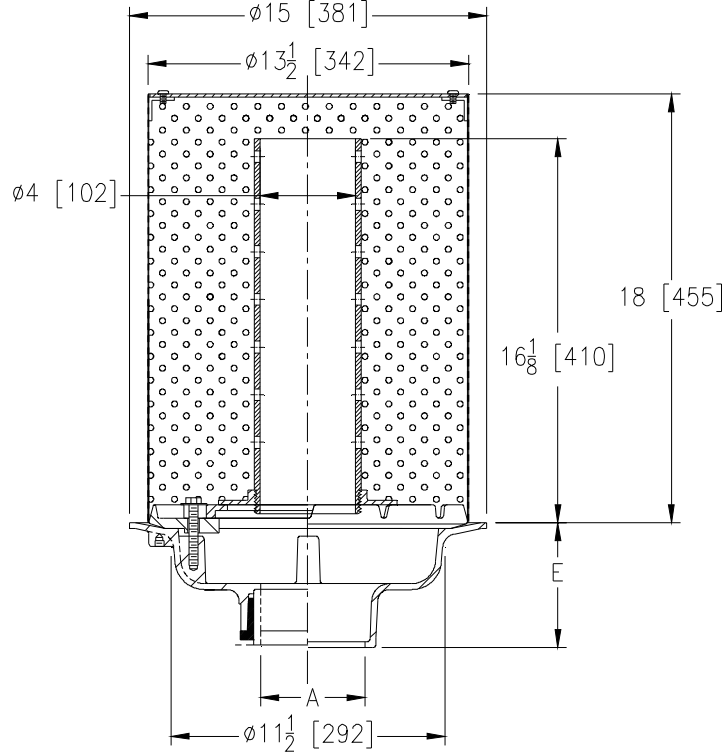

A Pipe Size In.	Approx. Wt. Lbs. [kg]
2,3,4 [51,76,102]	36 [16]
5,6 [127,152]	37 [17]
8 [203]	38 [18]

ENGINEERING SPECIFICATION: ZURN Z100-231

15 [381] Diameter roof drain. Dura-Coated cast iron body with combination membrane flashing clamp/gravel guard, 4 [102] standpipe and stainless steel perforated gravel guard with solid secured top.

OPTIONS (Check/specify appropriate options)

PIPE SIZE

2 thru 6,8 [51 thru 152,203]
2 thru 6,8 [51 thru 152,203]
2 thru 6,8 [51 thru 152,203]
2,3,4 [51,76,102]
6 [152]

(Specify size/type) OUTLET

_____ IC Inside Caulk
_____ IP Threaded
_____ NH No-Hub
_____ NL Neo-Loc
_____ NL Neo-Loc

E BODY HT. DIM.

5 1/4 [133]
3 3/4 [95]
5 1/4 [133]
4 9/16 [116]
5 7/16 [112]

PREFIXES

_____ Z D.C.C.I. Body

SUFFIXES

_____ -AC Angular Underdeck Clamp
_____ -AR Acid Resistant Epoxy Coated
_____ -C Underdeck Clamp
_____ -DE Deck Extension
_____ -DP Top-Set® Deck Plate (Replaces both the -C and -R)
_____ -DR Top-Set® Drain Riser
_____ -DX Dex-o-tex Flange
_____ -E Static Extension 1 [25] thru 4 [102] (Specify Ht.)
_____ -EB Top-Set® Adjustable Extension Assembly

_____ -G Galvanized Cast Iron
_____ -R Roof Sump Receiver
_____ -SC Secondary Clamp Collar
_____ -VP Vandal-Proof Secured Top
_____ -90 90° Threaded Side Outlet Body
(2 thru 6 [51 or 152])

*REGULARLY FURNISHED UNLESS OTHERWISE SPECIFIED

REV. DATE: 02/16/11 C.N. NO. 120877

DWG. NO. 304562 PRODUCT NO. Z100-231

ZURN INDUSTRIES, LLC ♦ SPECIFICATION DRAINAGE OPERATION ♦ 1801 Pittsburgh Ave. ♦ Erie, PA 16514

Phone: 814/455-0921 ♦ Fax: 814/454-7929 ♦ World Wide Web: www.zurn.com

In Canada: ZURN INDUSTRIES LIMITED ♦ 3544 Nashua Drive ♦ Mississauga, Ontario L4V1L2 ♦ Phone: 905/405-8272 Fax: 905/405-1292