



Z-100-129

SPECIFICATION SHEET

15" [381] DIAMETER COMBINATION MAIN ROOF DRAIN/PLANTING AREA DRAIN

TAG _____

Dimensional Data (inches and [mm]) are Subject to Manufacturing Tolerances and Change Without Notice

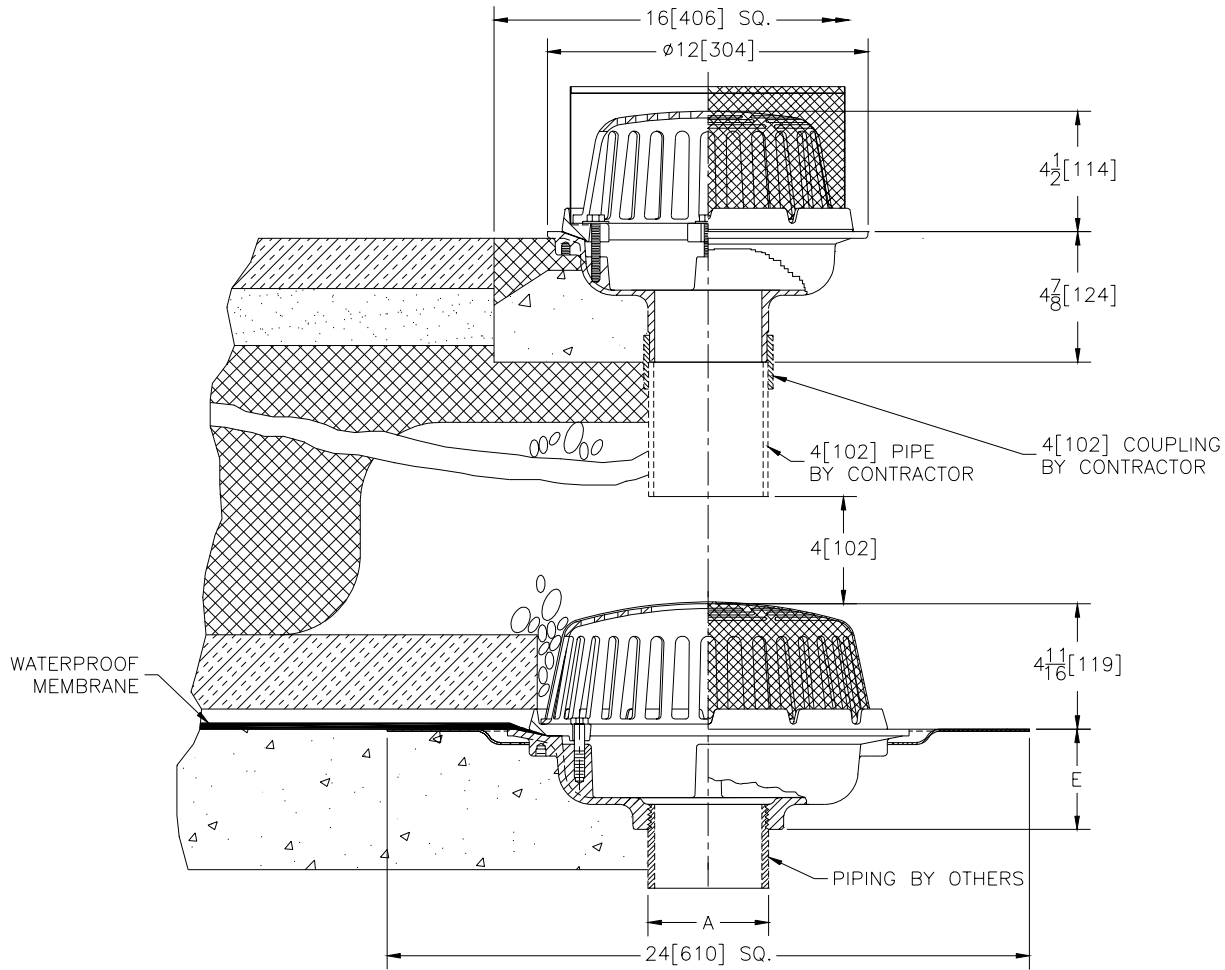

A- Pipe Size In.	Approx. Wt. Lbs. [kg]	Top Dome Open Area Sq. In. [cm ²]
2-3-4 [50-75-100]	26 [12]	78 [503]
5-6 [125-150]	27 [12]	
8 [200]	28 [13]	
10 [250]	30 [14]	

ENGINEERING SPECIFICATION: ZURN Z-100-129 15 [381] Diameter roof drain. Dura-Coated cast iron body with combination membrane flashing clamp/gravel guard, low silhouette dome with stainless steel mesh screen over dome and roof sump receiver in combination with upper dome type planting area drain, Dura-Coated cast iron body with bottom outlet complete with combination membrane flashing clamp/gravel guard, low silhouette aluminum dome and stainless steel mesh screen over dome.

OPTIONS (Check/specify appropriate options)

PIPE SIZE

2 thru 6, 8, 10 [50 thru 150, 200, 250]

(Specify size/type) **OUTLET**

_____ IP Threaded

E BODY HT. DIM.

3 3/4 [95]

SUFFIXES

- _____ -AC Angular Underdeck Clamp
- _____ -AR Acid Resistant Epoxy Coated Finish
- _____ -C Underdeck Clamp
- _____ -G Galvanized Cast Iron
- _____ -VP Vandal Proof Secured Top
- _____ -XJ Vertical Expansion Joint (See Z-190)

REV. A DATE: 08/05/96 C.N. NO. 75428

DWG. NO. P-14317 PRODUCT NO. Z-100-129