



Z1174-79

ADJUSTABLE ENCLOSED RECESSING RECEIVER FOR
COMBINED GREASE AND SOLIDS INTERCEPTOR W/
ANCHOR FLANGE

SPECIFICATION SHEET

TAG _____

Dimensional Data (inches and [mm]) are Subject to Manufacturing Tolerances and Change Without Notice

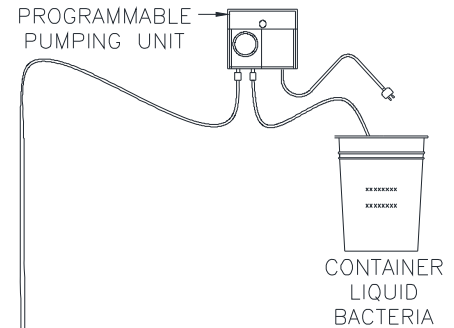
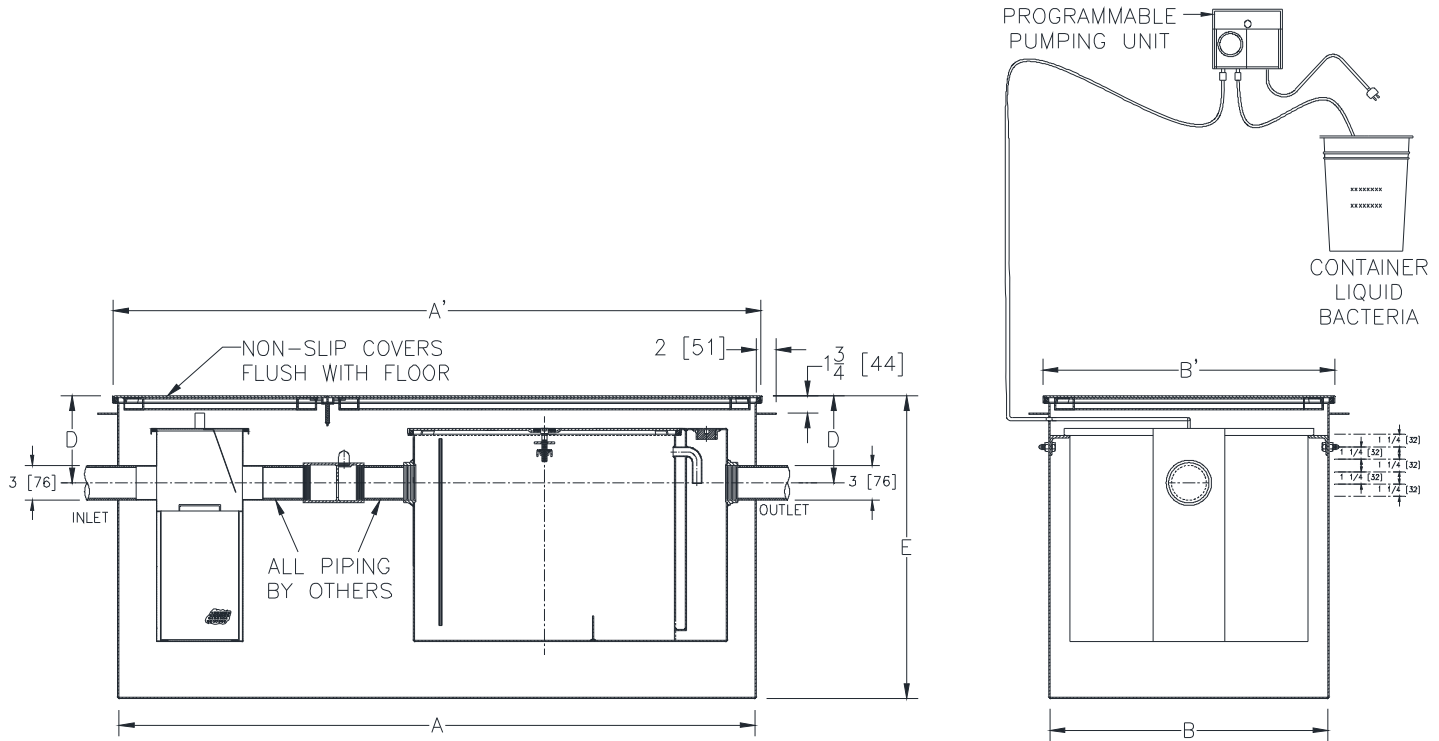

Size	Dimensions In Inches [mm]					
	A	A'	B	B'	D	E
800	64 [1626]	65-3/8 [1660]	28-5/8 [727]	30 [762]	11-3/4 [298]	33-1/2 [851]

ENGINEERING SPECIFICATION: ZURN Z1174-79
Acid Resistant Epoxy Coated Recessing receiver, enclosed type, equipped with adjustable support brackets and gasketed aluminum non-skid covers. Complete with Z1174 Grease Interceptor and Z1183 Solids Interceptor. For interceptor specifications see Z1174 & Z1183 specification sheets.

PREFIXES

_____ Z Acid Resistant Epoxy Coated Fabricated Steel*

Note: Not intended to be used with water proofing membrane.

* Regularly furnished unless otherwise specified.

Zurn Industries, LLC | Specification Drainage Operation
1801 Pittsburgh Avenue, Erie, PA U.S.A. 16502 · Ph. 855-663-9876, Fax 814-454-7929
In Canada | Zurn Industries Limited
3544 Nashua Drive, Mississauga, Ontario L4V 1L2 · Ph. 905-405-8272, Fax 905-405-1292
www.zurn.com

Rev. -
Date: 05/22/14
C.N. No. 131011
Prod. | Dwg. No. Z1174-79