



**Z887-24-96**

24 X 24 X 48 [610 X 610 X 1219] SAND INTERCEPTOR

SPECIFICATION SHEET

TAG \_\_\_\_\_

Dimensional Data (inches and [ mm ]) are Subject to Manufacturing Tolerances and Change Without Notice

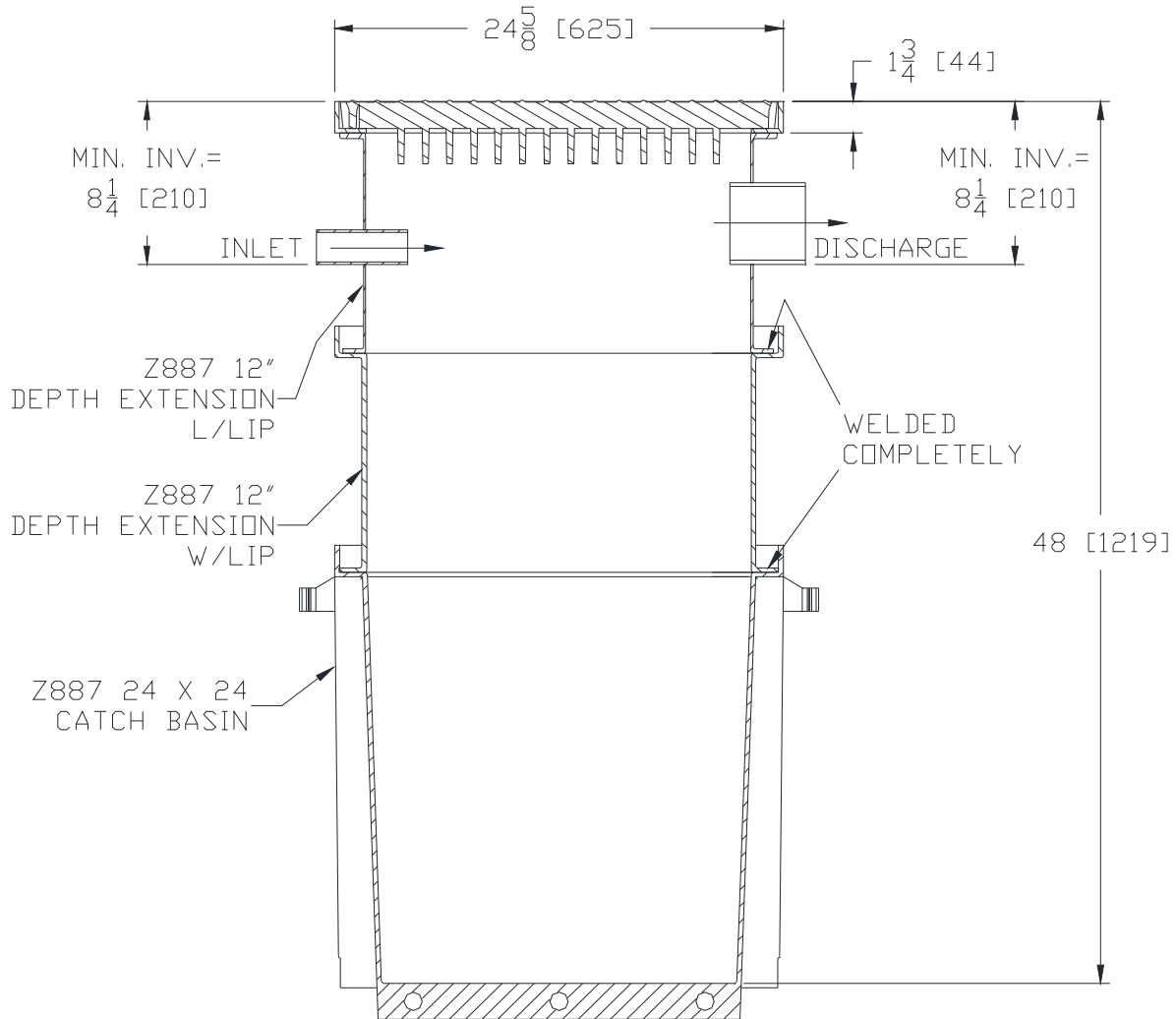

**ENGINEERING SPECIFICATION: Z887-24-96**

24" x 24" x 48" [610mm x 610mm x 1219mm] Sand Interceptor. Polyethylene body with Black Acid Resistant coated top frame, complete with heavy-duty Black Acid Resistant DIN Class F ductile iron slotted grate, 1-1/2" [38mm] inlet & 4" [102mm] outlet.

\* Regularly furnished unless otherwise specified.