

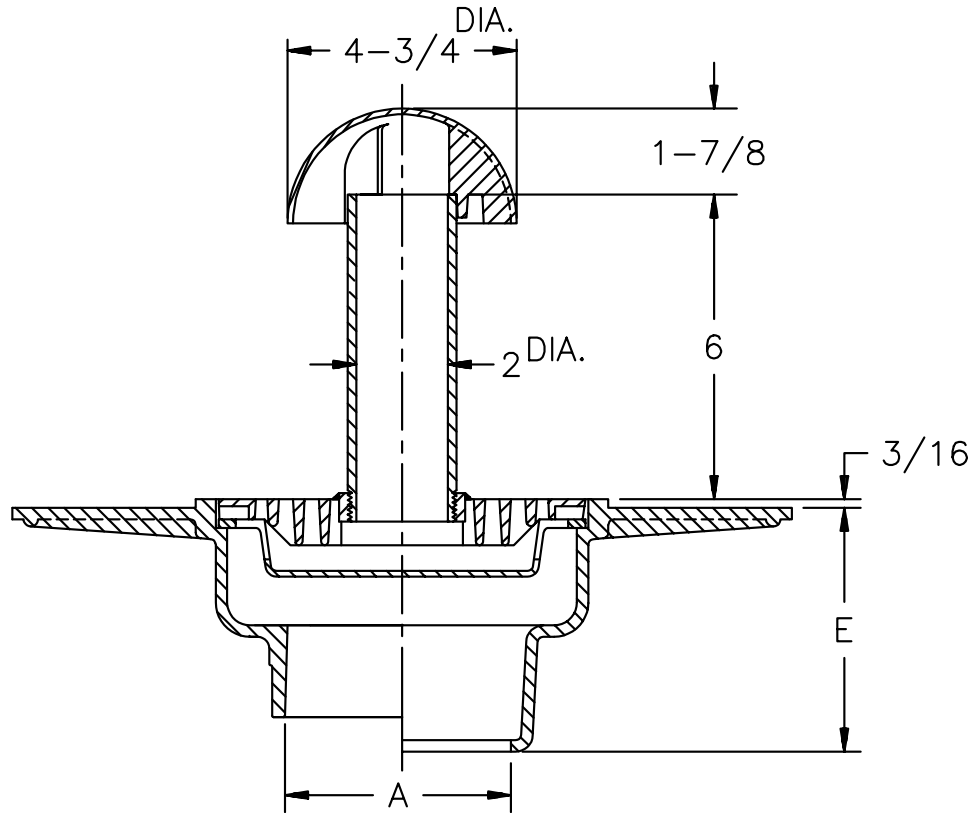

Z-530-78 DECK DRAIN WIDE FLANGE

TAG _____

Dimensional Data (inches and [mm]) are Subject to Manufacturing Tolerances and Change Without Notice



A- Pipe Size In.	Approx. Wt. Lbs.	Grate Open Area Sq. In.
2-3-4	53	17

ENGINEERING SPECIFICATION: ZURN Z-530-78 9" Top wide flange deck drain for latex decks, Dura-Coated cast iron body with latex troweling flange, flat grate, standpipe, dome and suspended sediment bucket.

OPTIONS (Check/specify appropriate options)

OUTLET (Specify type)

- _____ **IC** Inside Caulk
- _____ **IG** Inside Caulk w/Sealtrol Gskt.
- _____ **IP** Threaded
- _____ **NL** Neo-Loc

PIPE SIZE (Specify size)

- _____ 2", 3", 4"
- _____ 2", 3", 4"
- _____ 2", 3", 4"
- _____ 2", 3", 4"

'E' BODY HT. DIMENSION

- 5-1/2"
- 5-1/2"
- 4"
- 4-3/4"

PREFIXES

- _____ **Z-** D.C.C.I. Body and Grate*
- _____ **ZB-** D.C.C.I. Body with Polished Bronze Grate
- _____ **ZN-** D.C.C.I. Body with Polished Nickel Bronze Grate

SUFFIXES

- _____ **-C** Underdeck Clamp
- _____ **-D** Dome Grate
- _____ **-DG** Duresist Grate
- _____ **-L** (Less) Bucket
- _____ **-G** Galvanized Cast Iron
- _____ **-SC** Solid Cover
- _____ **-VP** Vandal Proof Secured Top
- _____ **-XJ** Expansion Joint (See Z-190)

*REGULARLY FURNISHED UNLESS OTHERWISE SPECIFIED

REV.	DATE: 10/17/91	C.N. NO. 67870
DWG. NO. P-13655 PRODUCT NO. Z-530-78		

ZURN INDUSTRIES, INC. ♦ SPECIFICATION DRAINAGE OPERATION ♦ 1801 Pittsburgh Ave. ♦ Erie, PA 16514

Phone: 814/455-0921 ♦ Fax: 814/454-7929 ♦ World Wide Web: www.zurn.com

In Canada: ZURN INDUSTRIES LIMITED ♦ 3544 Nashua Drive ♦ Mississauga, Ontario L4V1L2 ♦ Phone: 905/405-8272 Fax: 905/405-1292