



ZN-541-106

12" [305] DIAMETER HEAVY DUTY DRAIN

TAG _____

Dimensional Data (inches and [mm]) are Subject to Manufacturing Tolerances and Change Without Notice

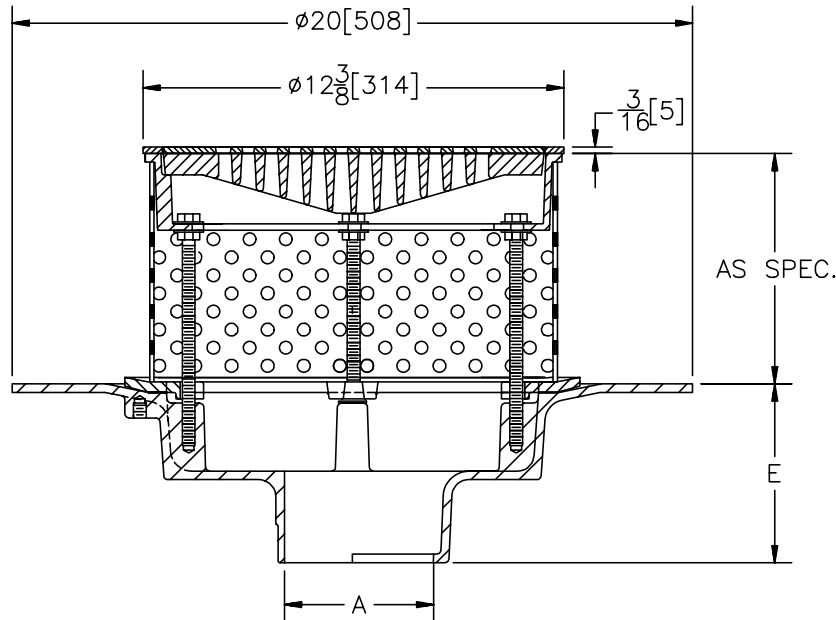

A- Pipe Size In.	Approx. Wt. Lbs. [kg]	Grate Open Area Sq. In. [cm ²]
2-3-4-5-6 [50-75-100-125-150]	52 [24]	29 [187]
8-10 [200-250]	54 [24]	

ENGINEERING SPECIFICATION: ZURN ZN-541-106 12" Diameter top drain, Dura-Coated 20" dia. wide flange cast iron body with bottom outlet, secondary clamp collar, frame for heavy duty cast iron slotted grate, #18 gage perforated stainless steel extension, nickel bronze frame and heel proof grate.

OPTIONS (Check/specify appropriate options)

PIPE SIZE

- 2 thru 6, 8, 10 [50 thru 150, 200, 250]
- 2 thru 6, 8, 10 [50 thru 150, 200, 250]
- 2 thru 6, 8, 10 [50 thru 150, 200, 250]
- 2 thru 6, 8, 10 [50 thru 150, 200, 250]
- 2 thru 4 [50 thru 100]

(Specify size/type) **OUTLET**

- _____ IC Inside Caulk
- _____ IG Inside Caulk w/Sealtrol Gskt.
- _____ IP Threaded
- _____ NH No-Hub
- _____ NL Neo-Loc

'E' BODY HT. DIM.

- 5 1/4 [133]
- 5 1/4 [133]
- 3 3/4 [95]
- 5 1/4 [133]
- 4 5/8 [117]

PREFIXES

- _____ Z- D.C.C.I. Body and Grate*
- _____ ZB- D.C.C.I. Body with Polished Bronze Grate (Add 3/16 [5] to 2 [51] Dim.)

SUFFIXES

- _____ -DG Duresist Grate
- _____ -G Galvanized Cast Iron
- _____ -P Trap Primer Connection
- _____ -S Secondary Strainer
- _____ -SS Stainless Mesh Liner for Bucket
- _____ -V Backwater Valve (See Z-1099)
- _____ -VP Vandal Proof Secured Top
- _____ -Y Bucket

REV.	DATE: 8/10/95	C.N. NO. 72617
DWG. NO. P-14221 PRODUCT NO. ZN-541-106		

*REGULARLY FURNISHED UNLESS OTHERWISE SPECIFIED