



Z-125-98
8 3/8 [213] DIAMETER ROOF DRAIN
LOW SILHOUETTE DOME

SPECIFICATION SHEET

TAG _____

Dimensional Data (inches and [mm]) are Subject to Manufacturing Tolerances and Change Without Notice

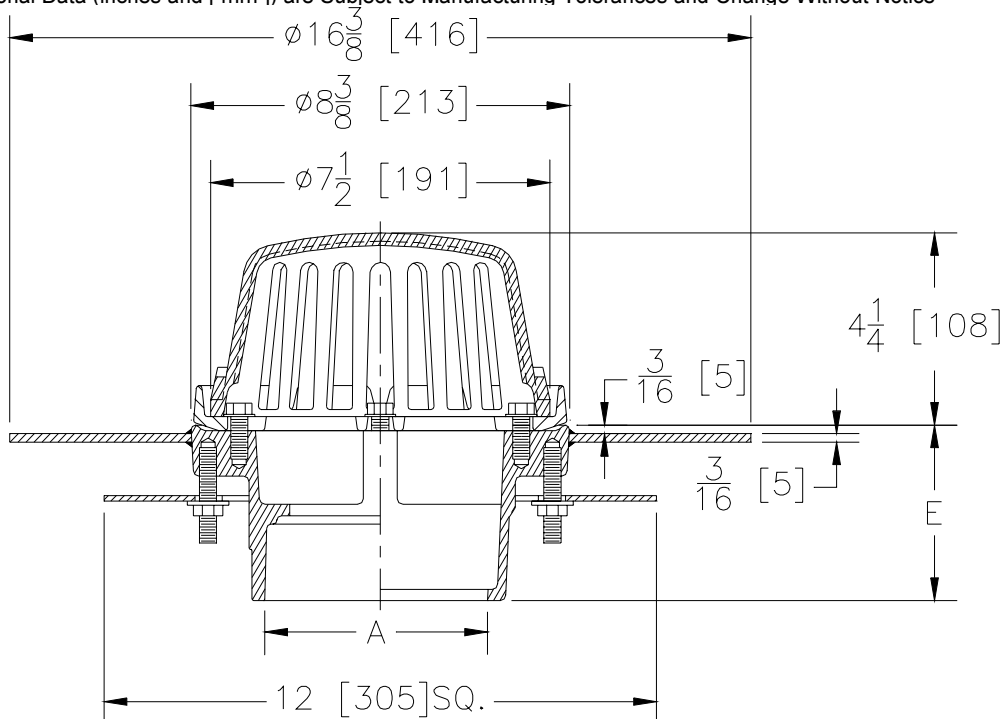

A- Pipe Size In.	Approx. Wt. Lbs. [kg]	Dome Open Area Sq. In. [cm ²]
2-3-4 [50-75-100]	14 [6]	43 [277]

ENGINEERING SPECIFICATION: ZURN Z-125-98-83/8 [213] Diameter roof drain, galvanized cast iron body with combination membrane flashing clamp/gravel guard, underdeck clamp, Dex-o-tex Flange and low silhouette aluminum dome.

OPTIONS (Check/specify appropriate options)

PIPE SIZE

- 2, 3, 4 [50, 75, 100]
- 2, 3, 4 [50, 75, 100]
- 2, 3, 4 [50, 75, 100]
- 2, 3, 4 [50, 75, 100]

(Specify size/type) **OUTLET**

- ___ IC Inside Caulk
- ___ IP Threaded
- ___ NH No-Hub
- ___ NL Neo-Loc

E' BODY HT. DIM.

- 3 7/8 [98]
- 2 5/8 [67]
- 3 7/8 [98]
- 4 5/8 [117]

PREFIXES

- ___ Z- D.C.C.I. Body with Dome*
- ___ ZRB- D.C.C.I. Body with Plain Bronze Dome

SUFFIXES

- ___ -AR Acid Resistant Epoxy Coated Finish
- ___ -BS Bronze Mesh Screen Over Dome
- ___ -E Static Extension 1 [25] thru 4 [102] (Specify Ht.)
- ___ -R Roof Sump Receiver
- ___ -SC Secondary Clamping Collar
- ___ -SS Stainless Steel Mesh Screen Over Dome
- ___ -VP Vandal Proof Secured Top
- ___ -XJ Vertical Expansion Joint (See Z-190)
- ___ -5 10 [254] Diameter Drain Body (See Z-125)
- ___ -84 Stainless Steel Perforated Gravel Guard
- ___ -85 Stainless Steel Perforated Extension
- ___ -89 2 [51] High External Water Dam
- ___ -90 90° Threaded Side Outlet Body

REV.	DATE: 3/6/02	C.N. NO. 88369
DWG. NO. P-14874 PRODUCT NO. Z-125-98		

*REGULARLY FURNISHED UNLESS OTHERWISE SPECIFIED