



ZN532

12-3/8 [314] DIAMETER WIDE FLANGE FLOOR DRAIN WITH NICKEL BRONZE VENEER TOP

SPECIFICATION SHEET

TAG _____

Dimensional Data (inches and [mm]) are Subject to Manufacturing Tolerances and Change Without Notice

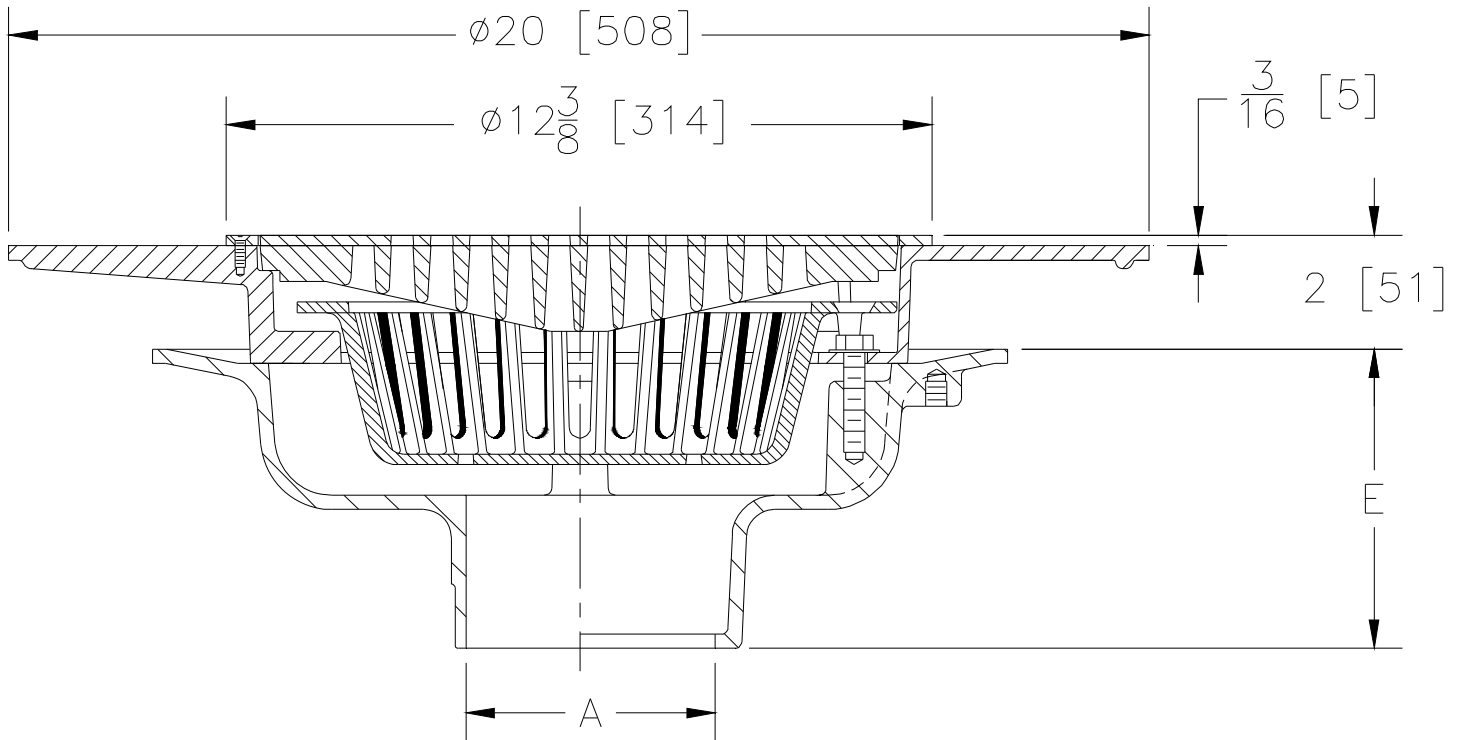

A- Pipe Size In. [mm]	Approx. Wt. Lbs. [kg]	Grate Open Area Sq. In. [cm ²]
2,3,4,6 [51,76,102,152]	54 [24]	30 [194]

ENGINEERING SPECIFICATION: ZURN ZN532

12-3/8" [314mm] Diameter wide flange floor drain, Dura-Coated cast iron body with bottom outlet, seepage pan and combination membrane flashing clamp/frame with latex troweling flange for heavy duty slotted grate, nickel bronze veneer frame and grate with suspended sediment bucket.

OPTIONS (Check/specify appropriate options)

PIPE SIZE

(Specify size/type) OUTLET

'E' BODY HT. DIM.

3,4,6 [51,76,102,152]	___ IC	Inside Caulk	5-1/4 [133]
3,4,6 [51,76,102, 152]	___ IG	Inside Gasket	5-1/4 [133]
2,3,4,6 [51,76,102,152]	___ NH	No-Hub	5-1/4 [133]
2,3,4 [51,76,102]	___ NL	Neo-Loc	4-1/2 [114]

SUFFIXES

- ___ -AR Acid Resistant Epoxy Coated Cast Iron
- ___ -DG Duresist Grate
- ___ -G Galvanized Cast Iron
- ___ -HP Heel Proof Grate
- ___ -TC Neo-Loc Test Cap Gasket
(2,3,4 [51,76,102] NL Bottom Outlet Only)
- ___ -TS Top Secured with Slotted Screws
- ___ -VP Vandal Proof Secured Top

* Regularly furnished unless otherwise specified.

Zurn Industries, LLC | Specification Drainage Operation
 1801 Pittsburgh Avenue, Erie, PA U.S.A. 16502 · Ph. 855-663-9876, Fax 814-454-7929
 In Canada | Zurn Industries Limited
 3544 Nashua Drive, Mississauga, Ontario L4V 1L2 · Ph. 905-405-8272, Fax 905-405-1292
www.zurn.com

Rev. B
 Date: 10/06/2017
 C.N. No. 138505
 Prod. | Dwg. No. ZN532