



Z1761-PB

SPECIFICATION SHEET

24 5/16 [618] SQUARE KETTLE DRAIN W/ 8 [203] SUMP DEPTH AND PERFORATED BUCKET

TAG _____

Dimensional Data (inches and [mm]) are Subject to Manufacturing Tolerances and Change Without Notice

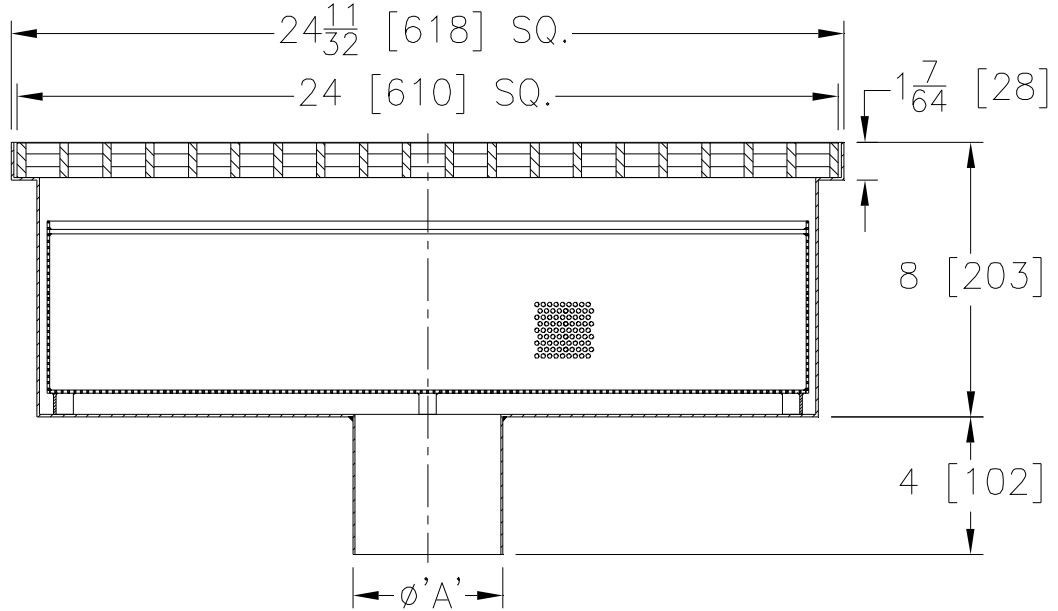

A Pipe Size In.	Approx. Wt. Lbs. [kg]	Grate Open Area Sq. In. [cm ²]
4-6-8[102-152-203]	72 [33]	425 [2742]

ENGINEERING SPECIFICATION: ZURN ZS1761-PB
24 5/16 [618] Square x 8 [203] deep, 14 gage, All Type 304 (CF8) Stainless Steel light duty Kettle Drain with, loose set full grate, and perforated sediment bucket.

OPTIONS (Check/specify appropriate options)

PIPE SIZE _____ (Specify size) **OUTLET**
4-6-8[102-152-203] _____ NH No-Hub

PREFIXES

- _____ Z A.R.E. Coated Fabricated Steel Body and Type 304 (CF8) Stainless Steel Grate
- _____ ZS Type 304 (CF8) Stainless Steel Body and Grate*
- _____ ZM Type 316 (CF8M) Stainless Steel Body and Grate

REV.	DATE: 9/8/06	C.N. NO. 95559
DWG. NO. 82869		PRODUCT NO. Z1761-PB

*REGULARLY FURNISHED UNLESS OTHERWISE SPECIFIED