



# Z-1455-75

## FLOOR CLEANOUT WITH FLASHING FLANGE

SPECIFICATION SHEET

TAG \_\_\_\_\_

Dimensional Data (inches and [ mm ]) are Subject to Manufacturing Tolerances and Change Without Notice

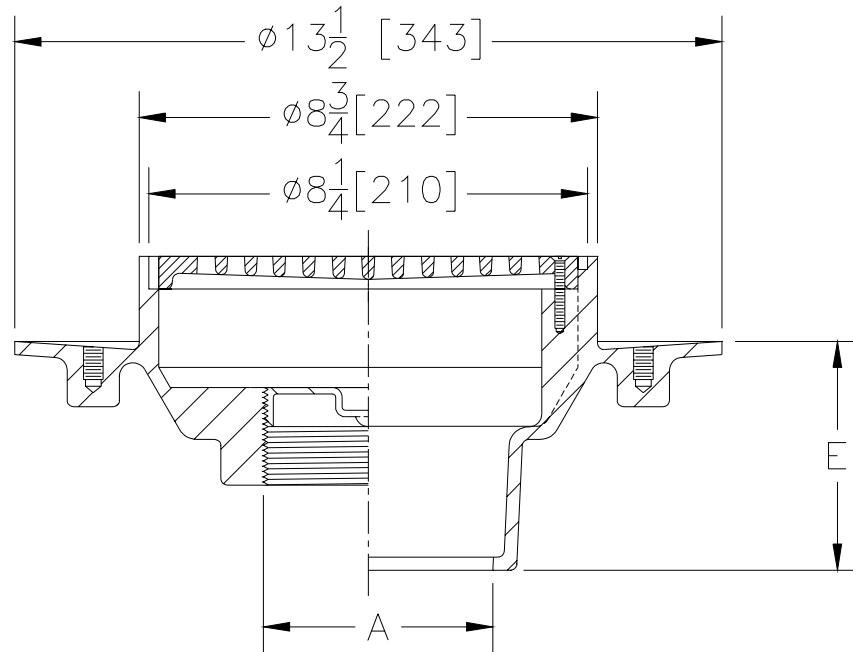

A Pipe Size Inches	Approx. Wt. Lbs [kg]
2-3 [50-75]	30 [14]
4 [100]	31 [14]

**ENGINEERING SPECIFICATION:** ZURN Z-1455-75 Floor cleanout, Dura-Coated cast iron body, gas and watertight ABS tapered thread plug, and non-tilt grate with plain finish complete with flashing flange.

**OPTIONS** (Check/specify appropriate options)

**PIPE SIZE**

- 2, 3, 4 [50, 75, 100]
- 2 [50]
- 3 [75]
- 4 [100]

(Specify size/type) **OUTLET**

- \_\_\_\_\_ IC Inside Caulk
- \_\_\_\_\_ IP Threaded
- \_\_\_\_\_ IP Threaded
- \_\_\_\_\_ IP Threaded

**'E' BODY HT. DIM.**

- 4 3/8 [111]
- 2 1/4 [57]
- 2 1/2 [64]
- 2 3/4 [70]

**PREFIXES**

- \_\_\_\_\_ Z- D.C.C.I.\*
- \_\_\_\_\_ ZB- D.C.C.I. with Polished Bronze Scoriated Top (Add 3/16 [5] to 1 3/4 [44] Dim.)
- \_\_\_\_\_ ZN D.C.C.I. with Polished Nickel Bronze Top (Add 3/16 [5] to 1 3/4 [44] Dim.)

**SUFFIXES**

- \_\_\_\_\_ -A Raised Head Cleanout Plug
- \_\_\_\_\_ -C Clamp Collar
- \_\_\_\_\_ -DC Duresist Cover
- \_\_\_\_\_ -G Galvanized Cast Iron
- \_\_\_\_\_ -VP Vandal Proof Secured Top

REV.	DATE: 10/23/95	C.N. NO. 73116
DWG. NO. P-14253		PRODUCT NO. Z-1455-75

\*REGULARLY FURNISHED UNLESS OTHERWISE SPECIFIED