



Z100-309

15 [381] DIAMETER ROOF DRAIN W/ SOLID TOP DOME WITH 4 [102] THREADED STANDPIPE, PERFORATED EXTENSION, AND Z181-HD UPPER DRAIN

SPECIFICATION SHEET

TAG _____

Dimensional Data (inches and [mm]) are Subject to Manufacturing Tolerances and Change Without Notice

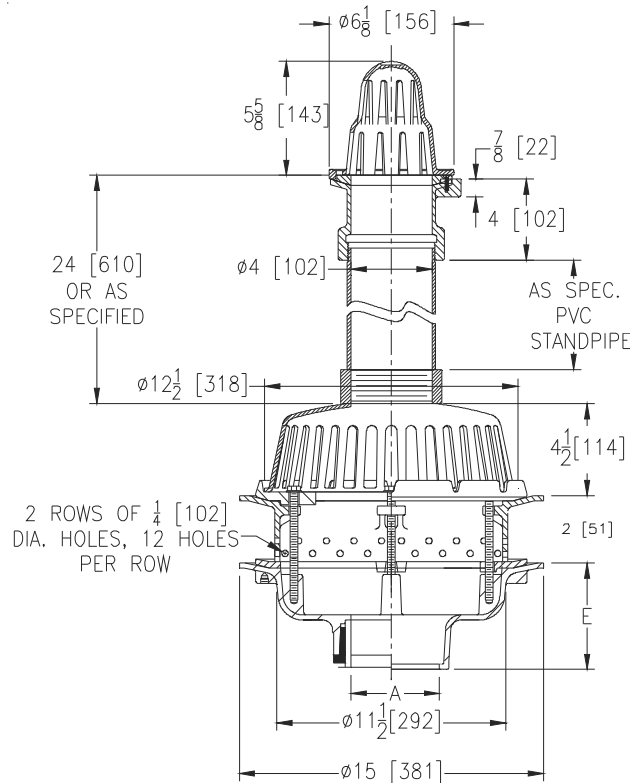

A Pipe Size In. [mm]	Approx. Wt. Lbs. [kg]	Dome Open Areas Sq. In. [cm ²]	
2, 3, 4 [51, 76, 102]	36 [16]	Upper	Lower
5, 6 [127, 152]	37 [17]	20 [129]	103 [665]
8 [203]	38 [17]		

ENGINEERING SPECIFICATION: ZURN Z100-309

15" [381mm] Diameter roof drain. Dura-Coated cast iron body with combination membrane flashing clamp/gravel guard, low silhouette solid top dome with threaded pipe coupling adaptor, 4" [102mm] PVC Sch 80 threaded standpipe, cast iron extension with 1/4" [6.3] diameter holes, secondary clamp collar, and Z181-HD upper drain assembly.

OPTIONS (Check/specify appropriate options)

PIPE SIZE

- 2, 3, 4, 5, 6, 8 [51, 76, 102, 127, 152, 203]
- 2, 3, 4, 5, 6, 8 [51, 76, 102, 127, 152, 203]
- 2, 3, 4, 5, 6, 8 [51, 76, 102, 127, 152, 203]
- 2, 3, 4 [51, 76, 102]
- 6 [152]

(Specify size/type) OUTLET

- _____ IC Inside Caulk
- _____ IP Threaded
- _____ NH No-Hub
- _____ NL Neo-Loc
- _____ NL Neo-Loc

E BODY HT. DIM.

- 5-1/4 [133]
- 3-3/4 [95]
- 5-1/4 [133]
- 4-9/16 [116]
- 5-7/16 [112]

PREFIXES

- _____ ZRB D.C.C.I. Body with Plain Bronze Dome*
- _____ ZB D.C.C.I. Body with Polished Bronze Dome
- _____ ZN D.C.C.I. Body with Polished Nickel Bronze Dome

SUFFIXES

- _____ -AC Angular Underdeck Clamp
- _____ -AR Acid Resistant Epoxy Coated
- _____ -C Underdeck Clamp
- _____ -DE Deck Extension
- _____ -DP Top-Set® Deck Plate (Replaces both the -C and -R)
- _____ -DR Top-Set® Drain Riser
- _____ -DX Dex-O-Tex Flange (Lower Body)
- _____ -EB Top-Set® Adjustable Extension Assembly
- _____ -G Galvanized Cast Iron
- _____ -GD Galvanized Cast Iron Dome (Lower Dome)
- _____ -R Roof Sump Receiver
- _____ -SA Stabilizer Assembly (see 1036)
- _____ -SS Mesh Over Domes
- _____ -VP Vandal-Proof Secured Top
- _____ -90 90° Threaded Side Outlet Body (2, 3, 4, 5, 6 [51, 76, 102, 127, 152])

* Regularly furnished unless otherwise specified.