



# Z100-293

15 [381] DIAMETER MAIN ROOF DRAIN W/ PERFORATED STANDPIPE, GRAVEL GUARD, & STABILIZER ASSEMBLY FOR 6 [152] OUTLET

SPECIFICATION SHEET

TAG \_\_\_\_\_

Dimensional Data (inches and [ mm ]) are Subject to Manufacturing Tolerances and Change Without Notice

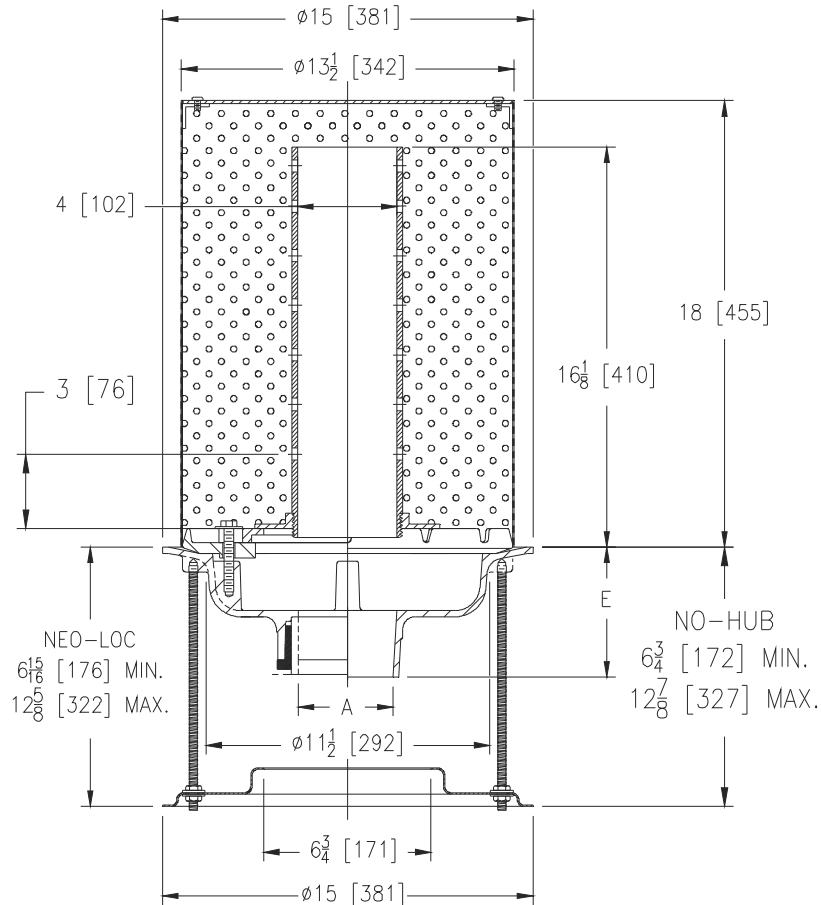

A Pipe Size In.	Approx. Wt. Lbs. [kg]
6 [152]	36 [16]

### ENGINEERING SPECIFICATION: ZURN Z100-293

15 [381] Diameter roof drain. Dura-Coated cast iron body with combination membrane flashing clamp/gravel guard, 4 [102] standpipe, stainless steel perforated gravel guard with solid secured top, and stabilizer assembly for 6 [152] outlet.

### OPTIONS (Check/specify appropriate options)

#### PIPE SIZE

6 [152]  
6 [152]

#### (Specify size/type) OUTLET

\_\_\_\_ NH No-Hub  
\_\_\_\_ NL Neo-Loc

#### E BODY HT. DIM.

5-1/4 [133]  
5-7/16 [138]

#### PREFIXES

\_\_\_\_ Z D.C.C.I. Body

#### SUFFIXES

\_\_\_\_ -AR Acid Resistant Epoxy Coated  
 \_\_\_\_ -DX Dex-o-tex Flange  
 \_\_\_\_ -E Static Extension 1 [25] thru 4 [102] (Specify Ht.)  
 \_\_\_\_ -G Galvanized Cast Iron  
 \_\_\_\_ -R Roof Sump Receiver  
 \_\_\_\_ -SC Secondary Clamp Collar  
 \_\_\_\_ -VP Vandal-Proof Secured Top

\* Regularly furnished unless otherwise specified.