



Z1188-152

SPECIFICATION SHEET

LARGE CAPACITY OIL INTERCEPTOR W/ HEAVY-DUTY COVER, ANCHOR FLANGE & 40 [1016] HIGH EXTENSION

TAG _____

Dimensional Data (inches and [mm]) are Subject to Manufacturing Tolerances and Change Without Notice

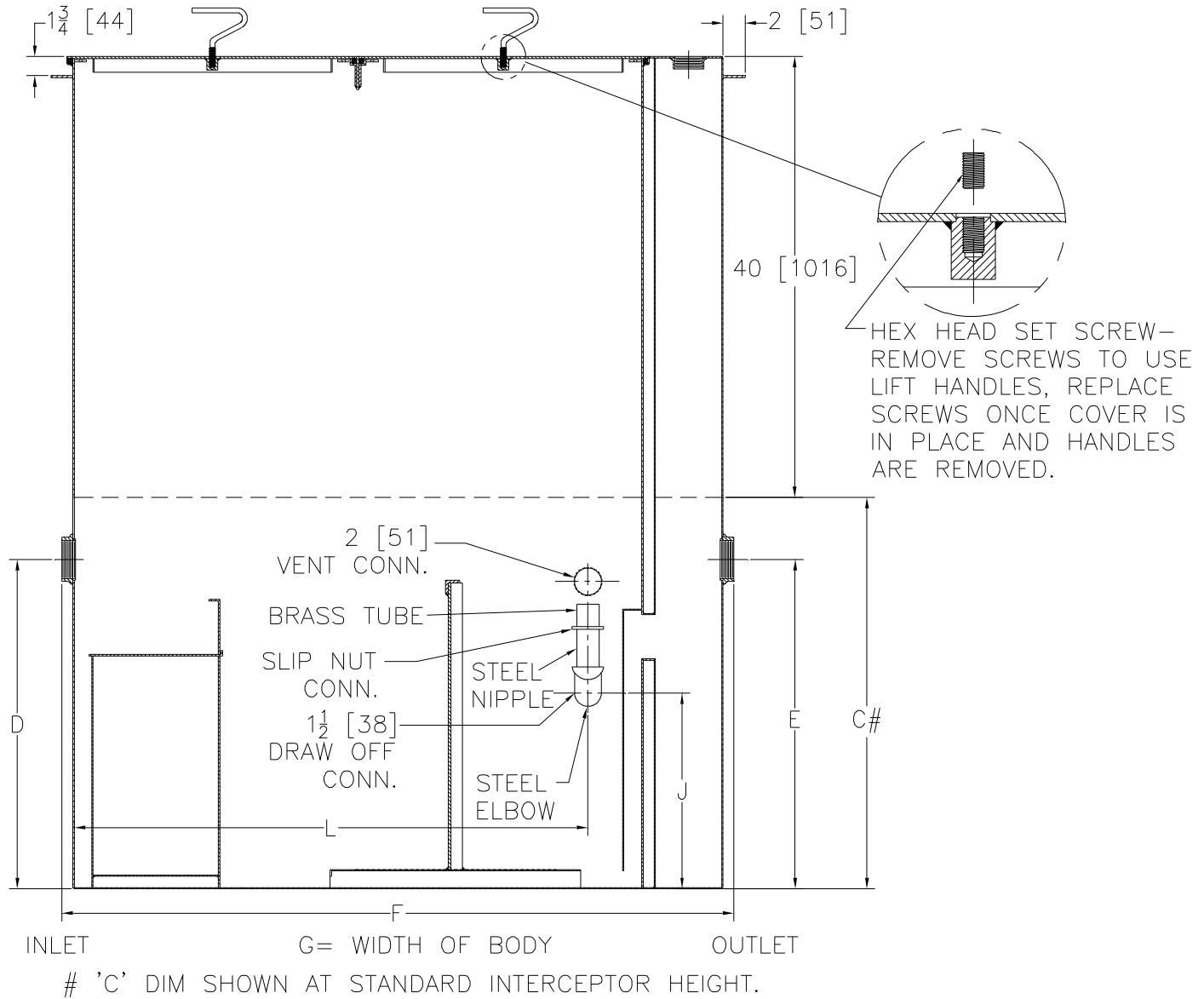

Flow Rate	Inlet/Outlet	Water Capacity	App. Wt.	No. of Covers	Dimensions In Inches					
					C	D/E	F	G	J	L
200[757]	4 [102]	265 [1003]	1620 [735]	2	35 1/2 [901]	29 7/8 [759]	61 [1549]	43 5/8 [2286]	17 3/4 [451]	46 5/8 [1184]

ENGINEERING SPECIFICATION: ZURN Z1188-152

Large capacity Acid Resistant Coated interior and exterior fabricated steel oil interceptor, with bronze cleanout plug and visible double wall trap seal, anchor flange, removable combination pressure equalizing/flow diffusing baffle and sediment bucket, horizontal baffle, adjustable oil drawoff, vent connections either side and 40 [1016] high integral extension. Complete with secured gasketed non-skid heavy-duty traffic cover rated at 10,000 lbs [4536 Kg.] maximum safe live load with removable lift handles and flow control fitting. Regularly furnished with inlet and outlet in high position.

OPTIONS (Check/specify appropriate options)

PREFIXES

___ Z Acid Resistant Coated Fabricated Steel*

REV.	DATE: 02/28/09	C.N. NO. 99703
DWG. NO. P-15669	PRODUCT NO. Z1188-152	

*REGULARLY FURNISHED UNLESS OTHERWISE SPECIFIED