



ZN1400-HD-SG

"LEVEL-TROL" ADJUSTABLE CLEANOUT W/ EXTRA HEAVY-DUTY SOLID GASKETED COVER

SPECIFICATION SHEET

TAG _____

Dimensional Data (inches and [mm]) are Subject to Manufacturing Tolerances and Change Without Notice

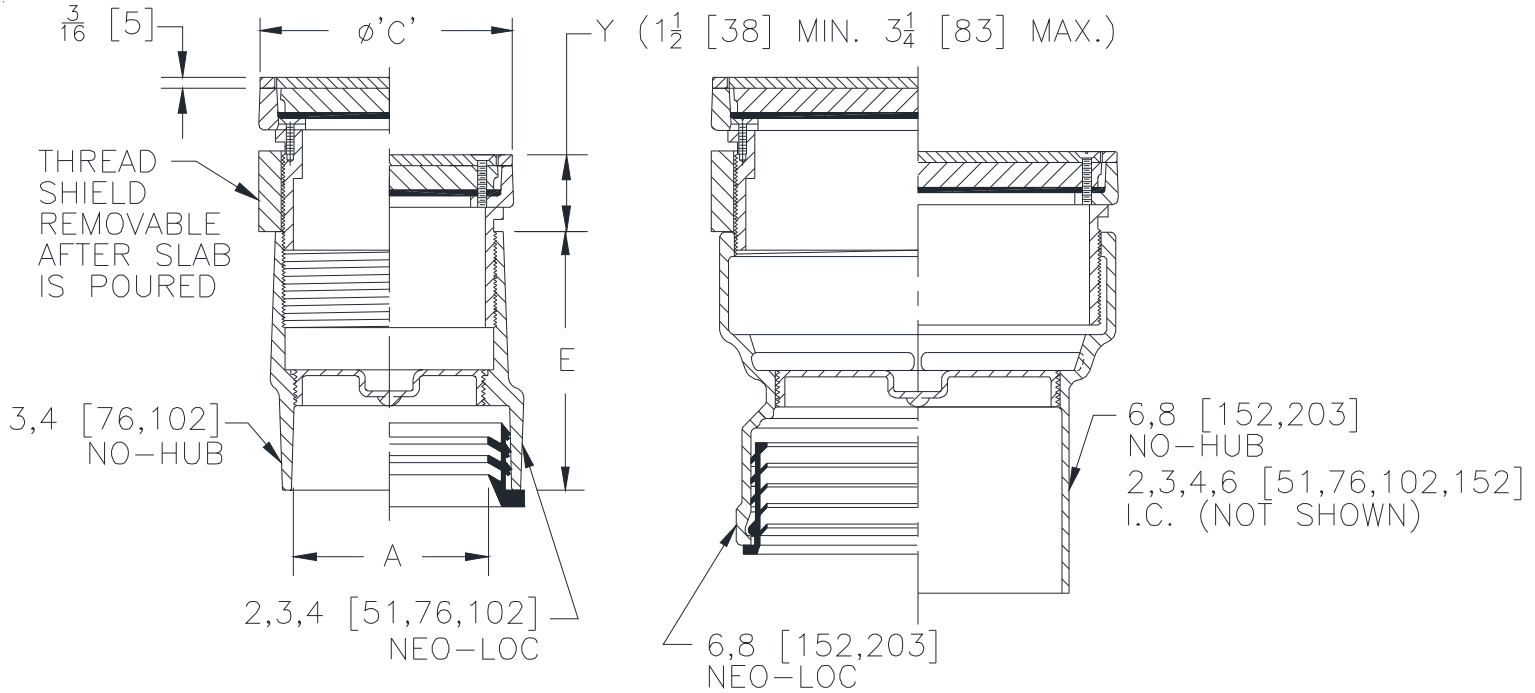

Dimensions In Inches [mm]			Approx. Wt. Lbs.[kg]
A-Pipe Size	C	E	
Inside Caulk			
2 [51]	6-1/8 [159]	6-7/8 [175]	16 [7]
3 [76]	6-1/8 [159]	6-7/8 [175]	16 [7]
4 [102]	7-1/4 [185]	6-7/8 [175]	19 [9]
6 [152]	9-1/4 [235]	6-7/8 [175]	23 [10]
No-Hub			
2 [51]	4-1/8 [105]	4-5/8 [117]	7 [3]
3 [76]	4-1/8 [105]	4-3/4 [121]	10 [4]
4 [102]	5-1/8 [130]	4-3/4 [121]	12 [5]
6 [152]	8-1/4 [210]	4-3/4 [121]	22 [10]
8 [203]	9-1/4 [235]	7-1/2 [191]	27 [12]
Neo-Loc			
2 [51]	4-1/8 [105]	4-3/4 [121]	10 [4]
3 [76]	5-1/8 [130]	4-3/4 [121]	12 [5]
4 [102]	5-1/8 [130]	4-3/4 [121]	14 [6]
6 [152]	8-1/4 [210]	5-7/8 [149]	22 [10]
8 [203]	9-1/4 [235]	6-1/2 [165]	27 [12]

ENGINEERING SPECIFICATION: ZURN ZN1400-HD-SG
 "Level-Trol" Adjustable floor cleanout, Dura-Coated cast iron body, frame and extra heavy-duty gasketed cover with gas and watertight ABS tapered thread plug, and round scoriated top with nickel bronze veneer frame and cover.

OPTIONS (Check/specify appropriate options)

PREFIXES

- ___ ZB D.C.C.I. with Polished Bronze Top
- ___ ZN D.C.C.I. with Polished Nickel Bronze Top*

SUFFIXES

- ___ -AR Acid Resistant Epoxy Coating
- ___ -BP Bronze Plug
- ___ -DC Duresist Cover
- ___ -G Galvanized Cast Iron
- ___ -K Anchor Flange
- ___ -KC Anchor Flange w/Clamping Collar
- ___ -VP Vandal Proof Secured Top
- ___ -T Square Top
- ___ -TC Neo-loc Test Cap Gasket (2,3,4 [51,76,102] NL Bottom Outlet Only)

PIPE SIZE

- 2,3,4,6 [51,76,102,152]
- 2,3,4,6,8 [51,76,102,152,203]
- 2,3,4,6,8 [51,76,102,152,203]

OUTLET (Specify size/type)

- ___ IC Inside Caulk
- ___ NH No-Hub
- ___ NL Neo-Loc

E BODY HT. DIM.

- See Chart
- See Chart
- See Chart

* Regularly furnished unless otherwise specified.