



Z511-86

SPECIFICATION SHEET

9 [229] DIAMETER HEAVY DUTY DRAIN W/ SOLID GASKETED COVER AND INDIRECT WASTE FUNNEL

TAG _____

Dimensional Data (inches and [mm]) are Subject to Manufacturing Tolerances and Change Without Notice

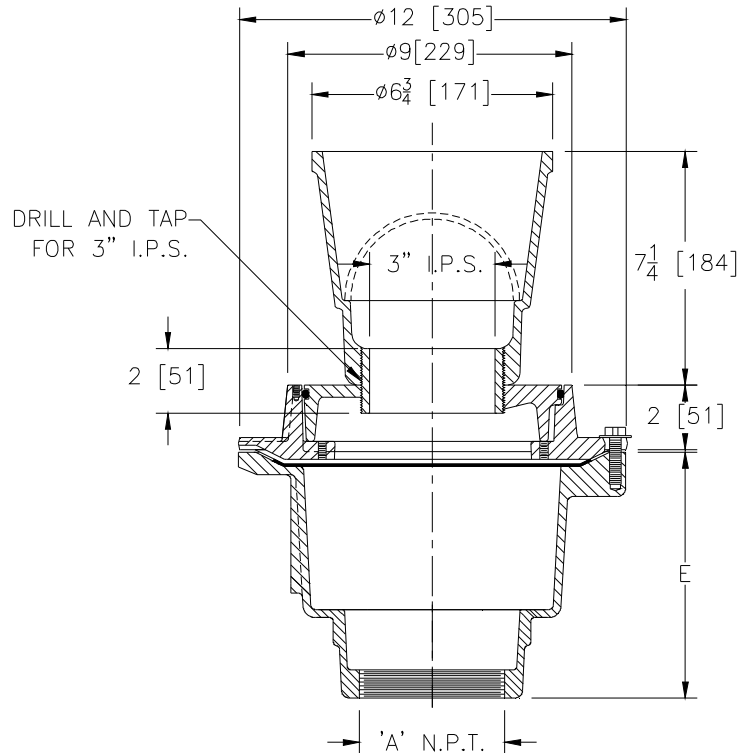

A- Pipe Size In.	Approx. Wt. Lbs. [kg]	Grate Open Area Sq. In. [cm ²]
3-4 [76-102]	49 [22]	15 [97]

ENGINEERING SPECIFICATION: ZURN Z511-86

9 [229] Diameter top drain, Dura-Coated cast iron deep sump body with bottom outlet, seepage pan and combination membrane flashing clamp and frame for solid gasketed cover, Indirect Waste funnel with Dura-Coated cast iron body, and bottom dome strainer.

OPTIONS (Check/specify appropriate options)

PIPE SIZE

3, 4 [76, 102]

(Specify size/type) OUTLET

____ IP Threaded

'E' BODY HT. DIM.

7 5/8 [195]

PREFIXES

- ____ Z D.C.C.I. Body and Grate*
- ____ ZB D.C.C.I. Body w/Polished Bronze Top
- ____ ZN D.C.C.I. Body w/Polished Nickel Bronze Top

SUFFIXES

- ____ -AR Acid Resisting Epoxy Coated Cast Iron
- ____ -DG Duresist Grate
- ____ -G Galvanized Cast Iron
- ____ -J Auxiliary Inlet Connection
(Specify 1 1/2 [38] or 2 [51] IP, Number & Location)
- ____ -P Trap Primer Connection
- ____ -S Secondary Strainer
- ____ -SS Stainless Mesh Liner for Bucket
- ____ -TS Top Secured with Slotted Screws
- ____ -V Backwater Valve
- ____ -VP Vandal-Proof Secured Top
- ____ -W Winter Closure Plug (see Z511)
- ____ -Y Sediment Bucket

REV. B DATE: 12/15/10 C.N. NO. 120669

DWG. NO. 302839 PRODUCT NO. Z511-86

*REGULARLY FURNISHED UNLESS OTHERWISE SPECIFIED

ZURN INDUSTRIES, LLC. ♦ SPECIFICATION DRAINAGE OPERATION ♦ 1801 Pittsburgh Ave. ♦ Erie, PA 16514

Phone: 814/455-0921 ♦ Fax: 814/454-7929 ♦ World Wide Web: www.zurn.com

In Canada: ZURN INDUSTRIES LIMITED ♦ 3544 Nashua Drive ♦ Mississauga, Ontario L4V1L2 ♦ Phone: 905/405-8272 Fax: 905/405-1292