



# Z107-106

SPECIFICATION SHEET

## 20 [508] WIDE DECK FLANGE ROOF DRAIN W/ ADJUSTABLE STANDPIPE AND GRAVEL GUARD W/ SECURED SOLID TOP

TAG \_\_\_\_\_

Dimensional Data (inches and [ mm ]) are Subject to Manufacturing Tolerances and Change Without Notice

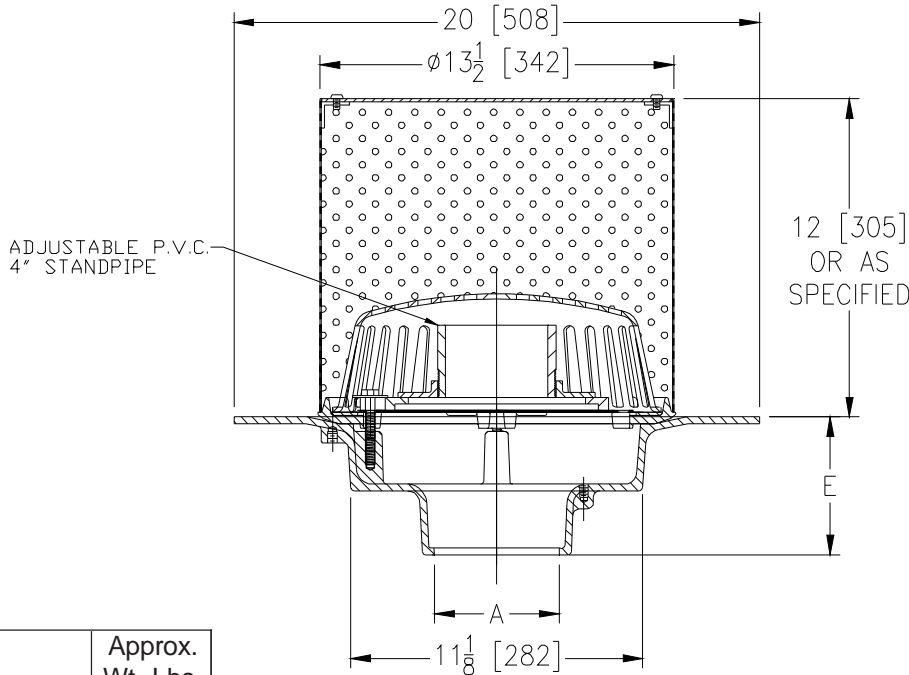

A Pipe Size In.	Approx. Wt. Lbs. [kg]
3, 4 [76, 102]	39 [18]
6, 8 [152, 203]	

**ENGINEERING SPECIFICATION:** ZURN Z107-106 20 [508] Wide deck flange roof drain. Dura-Coated cast iron body, clamping collar with integral gravel guard, waterlevel overflow adaptor, adaptor plate, adjustable P.V.C. 4" standpipe, secured Poly-Dome strainer, and stainless steel gravel guard with solid secured cover.

### OPTIONS (Check/specify appropriate options)

#### PIPE SIZE

- 3, 4, 6 [76, 102, 152]
- 3, 4 [76, 102]
- 3, 4, 6, 8 [76, 102, 152, 203]

#### (Specify size/type) OUTLET

- \_\_\_ IC Inside Caulk
- \_\_\_ IP Threaded
- \_\_\_ NH No-Hub

#### E BODY HT. DIM.

- 5-1/4 [133]
- 5-1/4 [133]
- 5-1/4 [133]

### PREFIXES

- \_\_\_ Z D.C.C.I. Body with Poly-Dome\*
- \_\_\_ ZA D.C.C.I. Body with Aluminum Dome
- \_\_\_ ZC D.C.C.I. Body with Cast Iron Dome
- \_\_\_ ZRB D.C.C.I. Body with Plain Bronze Dome

### SUFFIXES

- \_\_\_ -AC Angular Underdeck Clamp
- \_\_\_ -AR Acid Resistant Epoxy Coated
- \_\_\_ -C Underdeck Clamp
- \_\_\_ -E Static Extension 1 [25] thru 4 [102] (Specify Ht.)
- \_\_\_ -EA Adjustable Extension Assembly  
2-1/8 [54] thru 3-1/2 [89]
- \_\_\_ -G Galvanized Cast Iron
- \_\_\_ -GD Galvanized Cast Iron Dome (ZC Only)
- \_\_\_ -HD 6-3/4 [171] High Aluminum Dome Strainer  
(148 Sq. In. [955 cm<sup>2</sup>] Open Area)(ZA Only)
- \_\_\_ -SS Stainless Steel Mesh Screen Over Dome
- \_\_\_ -VP Vandal-Proof Secured Top
- \_\_\_ -XJ Vertical Expansion Joint (See Z190)
- \_\_\_ -85 Stainless Steel Perforated Extension

\*REGULARLY FURNISHED UNLESS OTHERWISE SPECIFIED

REV.	DATE: 09/19/11	C.N. NO. 122157
DWG. NO. 307639	PRODUCT NO. Z107-106	