

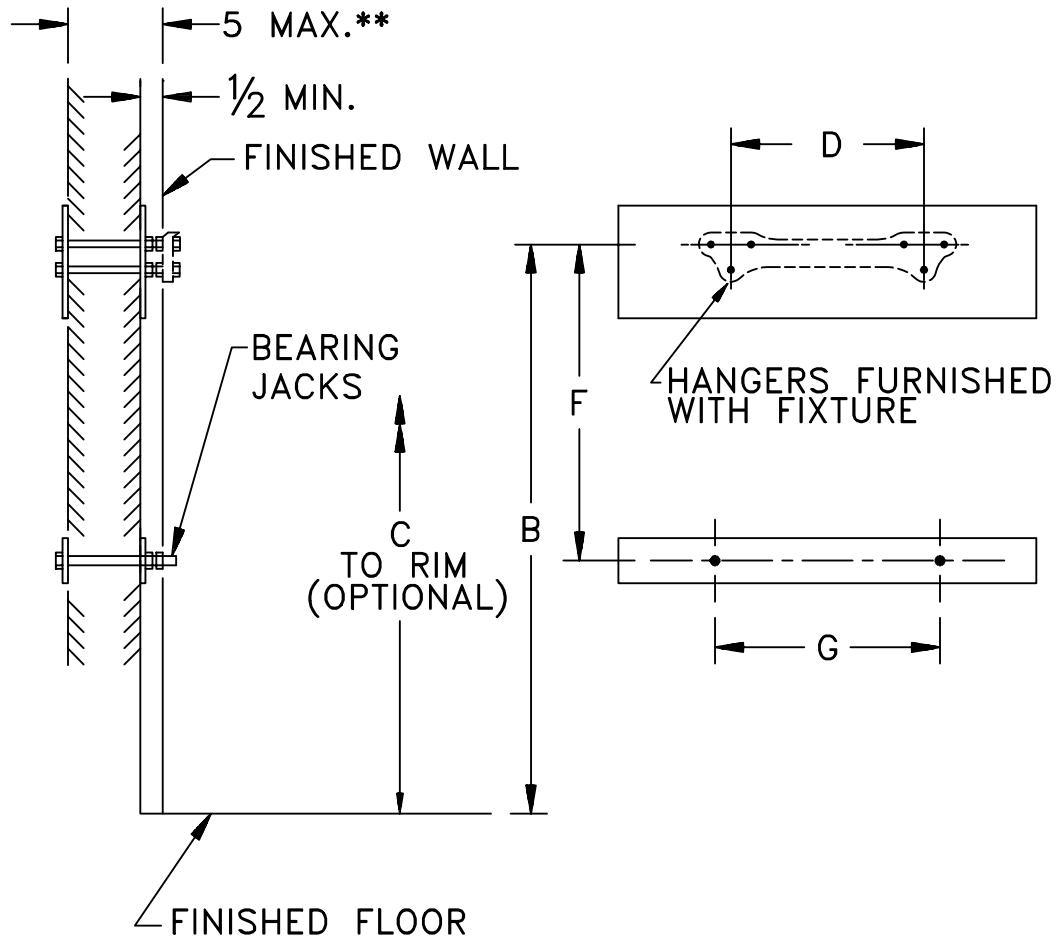

# Z-1259-BP PLATE SYSTEM Wall Supported

TAG \_\_\_\_\_

Dimensional Data (inches and [ mm ]) are Subject to Manufacturing Tolerances and Change Without Notice



\*\* WITH STANDARD STUD LENGTH OF 6.

Product No.	Approx. Wt. Lbs.
Z-1259-BP	24

**ENGINEERING SPECIFICATION:** ZURN Z-1259-BP Lavatory support. Complete with Dura-Coated support plate(s), and mounting fasteners.

## PRODUCT/DEFINITION

\_\_\_\_\_ **Z-1259-BP** Top Front and Back Plates with Studs and Bottom Front and Back Plates with Bearing Jacks

## PREFIXES

\_\_\_\_\_ **Z-** Dura-Coated Plate System\*

## SUFFIXES

\_\_\_\_\_ **-SL** Stud Length Over 6" (Specify Length)

\_\_\_\_\_ **-VP** Vandal Proof Trim

\*REGULARLY FURNISHED UNLESS OTHERWISE SPECIFIED, LETTER DIMENSIONS TO MEET FIXTURE REQUIREMENTS.

REV.	DATE: 9/20/91	C.N. NO. 67825
DRAWING NO. 56984	PRODUCT NO. Z-1259-BP	

ZURN INDUSTRIES, INC. ♦ SPECIFICATION DRAINAGE OPERATION ♦ 1801 Pittsburgh Ave. ♦ Erie, PA 16514

Phone: 814/455-0921 ♦ Fax: 814/454-7929 ♦ World Wide Web: www.zurn.com

In Canada: ZURN INDUSTRIES LIMITED ♦ 3544 Nashua Drive ♦ Mississauga, Ontario L4V1L2 ♦ Phone: 905/405-8272 Fax: 905/405-1292