



# Z100-E-EA-W2

15 [381] DIAMETER MAIN ROOF DRAIN W/ STATIC  
EXTENSION, ADJUSTABLE EXTENSION, AND 2 [51]  
INTERNAL WATER DAM

SPECIFICATION SHEET

TAG \_\_\_\_\_

Dimensional Data (inches and [ mm ]) are Subject to Manufacturing Tolerances and Change Without Notice

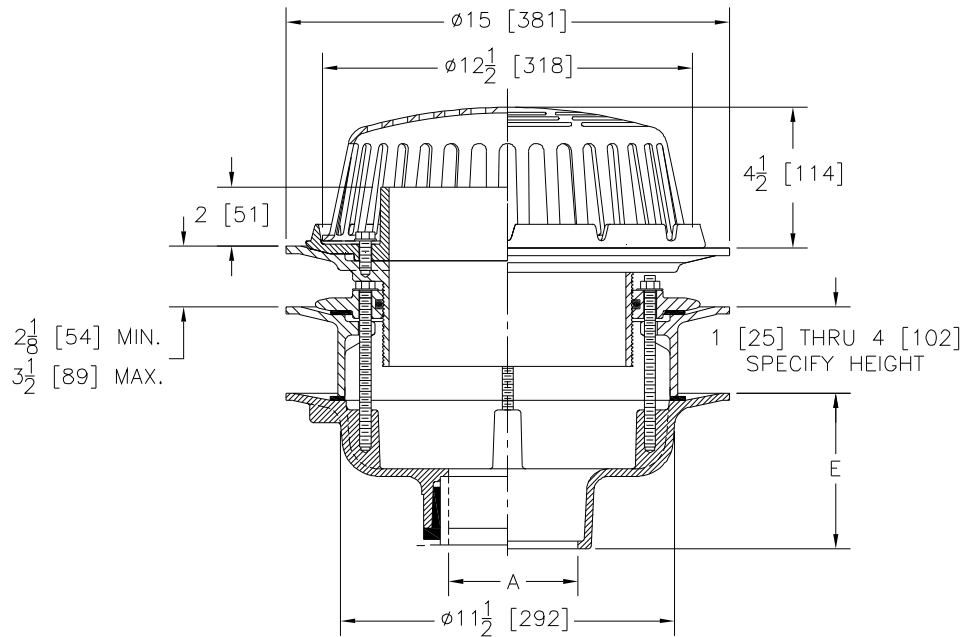

A Pipe Size in [mm]	Approx Wt. lbs [kg]	Dome Open Area in <sup>2</sup> [cm <sup>2</sup> ]
2,3,4 [51,76,102]	48 [22]	103 [665]
6 [152]	49 [22]	
8 [203]	50 [23]	

**ENGINEERING SPECIFICATION: ZURN Z100-E-EA-W2**  
15" [381mm] diameter roof drain. Dura-Coated cast iron body with combination membrane flashing clamp/gravel guard with 2" [51mm] high internal water dam, static extension, gasket, adjustable extension and low silhouette Poly-Dome.

**OPTIONS** (Check/specify appropriate options)

**PIPE SIZE**

- 3,4,6 [76,102,152]
- 2,3,4,6,8 [51,76,102,152,203]
- 2,3,4,6,8 [51,76,102,152,203]
- 2,3,4 [51,76,102]
- 6 [152]

(Specify size/type) **OUTLET**

- \_\_\_\_\_ IC Inside Caulk
- \_\_\_\_\_ IP Threaded
- \_\_\_\_\_ NH No-Hub
- \_\_\_\_\_ NL Neo-Loc
- \_\_\_\_\_ NL Neo-Loc

**E BODY HT. DIM.**

- 5-1/4 [133]
- 3-3/4 [95]
- 5-1/4 [133]
- 4-5/8 [117]
- 5-7/16 [138]

**PREFIXES**

- \_\_\_\_\_ Z D.C.C.I. Body with Poly-Dome\*
- \_\_\_\_\_ ZA D.C.C.I. Body with Aluminum Dome
- \_\_\_\_\_ ZC D.C.C.I. Body with Cast Iron Dome
- \_\_\_\_\_ ZRB D.C.C.I. Body with Plain Bronze Dome

**SUFFIXES**

- \_\_\_\_\_ -AC Angular Underdeck Clamp
- \_\_\_\_\_ -AR Acid Resistant Epoxy Coated
- \_\_\_\_\_ -C Underdeck Clamp
- \_\_\_\_\_ -DE Deck Extension (Includes Deck Plate -DP)
- \_\_\_\_\_ -DP Top-Set® Roof Deck Plate (Replaces both -C and -R)
- \_\_\_\_\_ -DR Top-Set® Drain Riser
- \_\_\_\_\_ -EB Top-Set® Adjustable Extension Assembly
- \_\_\_\_\_ -G Galvanized Cast Iron
- \_\_\_\_\_ -HD 6-3/4 [171] High Aluminum Dome (148 sq. in. [955 cm<sup>2</sup>] open area)
- \_\_\_\_\_ -R Roof Sump Receiver
- \_\_\_\_\_ -SC Secondary Clamping Collar
- \_\_\_\_\_ -SS Stainless Mesh Screen Over Dome
- \_\_\_\_\_ -ST Dome w/ Solid Top (ZA and ZC Only)
- \_\_\_\_\_ -TC Neo-Loc Test Cap Gasket (2,3,4 [51,76,102] NL Bottom Outlet Only)
- \_\_\_\_\_ -VP Vandal Proof Secured Top
- \_\_\_\_\_ -84 Stainless Steel Perforated Gravel Guard
- \_\_\_\_\_ -90 90° Threaded Side Outlet Body

\* Regularly furnished unless otherwise specified.