



# Z1172-RE

## LARGE CAPACITY GREASE INTERCEPTOR W/ RECESSED ENCLOSURE

SPECIFICATION SHEET  
TAG \_\_\_\_\_

Dimensional Data (inches and [ mm ]) are Subject to Manufacturing Tolerances and Change Without Notice

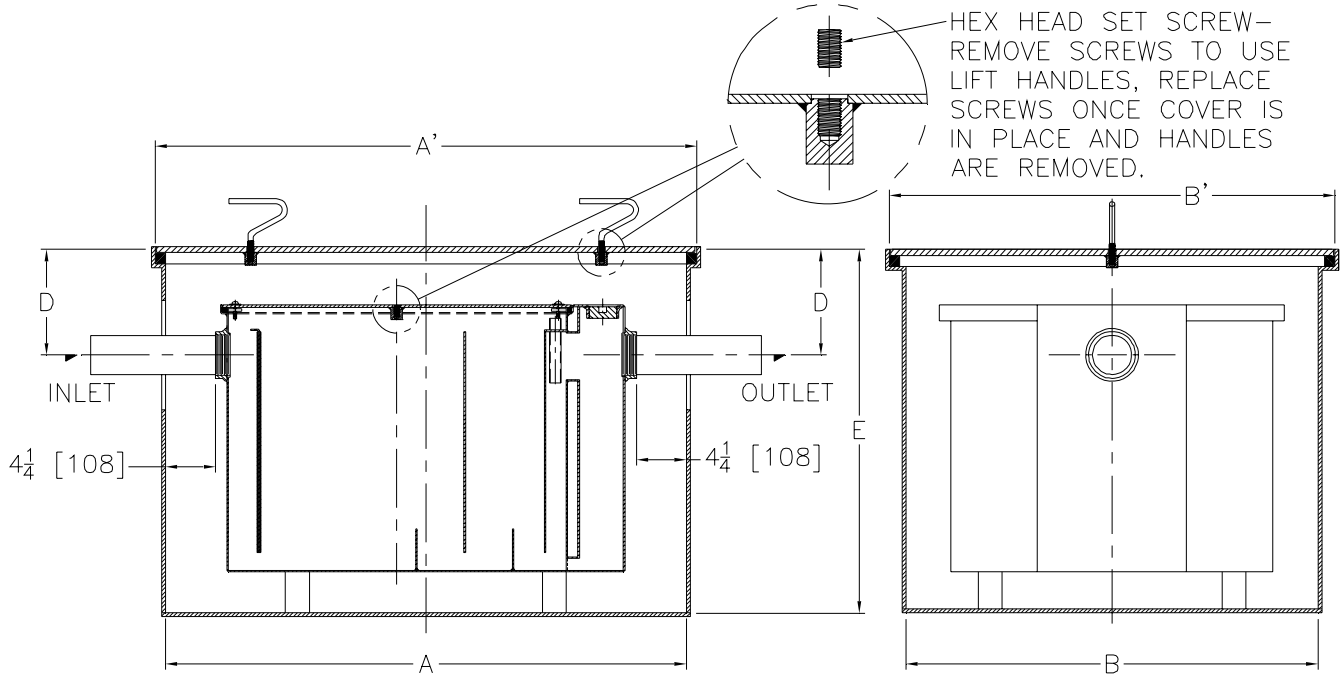

| Size | Inlet/<br>Outlet<br>Size** | Flow Rate<br>G.P.M.<br>[L] | Capacity          |                     | No. of<br>Covers | Approx.<br>Wt.<br>Lbs. [kg] | Dimension in Inches |               |              |               |             |              |
|------|----------------------------|----------------------------|-------------------|---------------------|------------------|-----------------------------|---------------------|---------------|--------------|---------------|-------------|--------------|
|      |                            |                            | Water<br>Gal. [L] | Grease<br>Lbs. [kg] |                  |                             | A                   | A'            | B            | B'            | D           | E            |
| 900  | 3 [76]                     | 75 [284]                   | 65 [246]          | 150 [68]            | 1                | 720 [327]                   | 44 1/4 [1124]       | 46 1/4 [1175] | 33 1/8 [841] | 35 1/8 [892]  | 9 [229]     | 31 1/4 [794] |
| 1000 | 3 [76]                     | 100 [379]                  | 110 [416]         | 200 [91]            | 1                | 830 [377]                   | 51 [1295]           | 53 [1346]     | 38 1/8 [968] | 40 1/8 [1019] | 8-1/2 [216] | 36 [914]     |

**ENGINEERING SPECIFICATION: ZURN Z1172-RE**

Large capacity interceptor with Acid Resistant Epoxy Coated Recessing Receiver, enclosed type, equipped with fixed support brackets and gasketed non-skid cover with removable lift handles. For interceptor specifications see Z1172 specification sheet. Only available with 900 & 1000 sizes.

**OPTIONS** (Check/specify appropriate options)

**PREFIXES**

\_\_\_\_ Z Acid Resistant Coated Fabricated Steel\*

**SUFFIXES**

- \_\_\_\_ -K Anchor flange 1 3/4 [44] down from top and 2 [51] wide.
- \_\_\_\_ -KC Anchor flange 1 3/4 [44] down from top and 2 [51] wide with clamp collar.
- \_\_\_\_ -L Angle type (Z1108-L) flow control device.
- \_\_\_\_ -T Cover recessed for tile/terrazzo. A3 [76] minimum extension height is required.

\*REGULARLY FURNISHED UNLESS OTHERWISE SPECIFIED

|                       |                             |                        |
|-----------------------|-----------------------------|------------------------|
| <b>REV. B</b>         | <b>DATE: 04/29/11</b>       | <b>C.N. NO. 121192</b> |
| <b>DWG. NO. 83366</b> | <b>PRODUCT NO. Z1172-RE</b> |                        |

ZURN INDUSTRIES, LLC. ♦ SPECIFICATION DRAINAGE OPERATION ♦ 1801 Pittsburgh Ave. ♦ Erie, PA 16514

Phone: 814455-0921 ♦ Fax: 814454-7929 ♦ World Wide Web: www.zurn.com

In Canada: ZURN INDUSTRIES LIMITED ♦ 3544 Nashua Drive ♦ Mississauga, Ontario L4V1L2 ♦ Phone: 905405-8272 Fax: 905405-1292