



# Z1910-23

8 X 8 [203 X 203] A.R.E. SANI-FLOR RECEPTOR 6 [152]  
SUMP DEPTH W/ ALUMINUM BUCKET

SPECIFICATION SHEET

TAG \_\_\_\_\_

Dimensional Data (inches and [ mm ]) are Subject to Manufacturing Tolerances and Change Without Notice

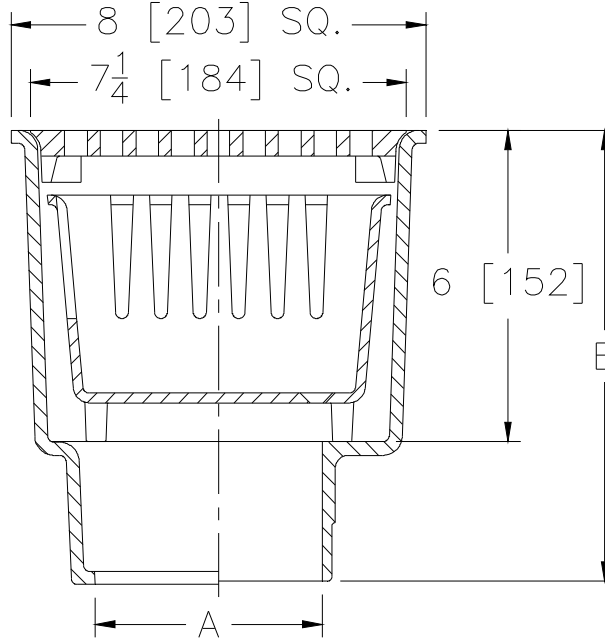

A Pipe Size In. [mm]	Approx Wt. Lbs. [kg]	Grate Open Area Sq. In. [cm <sup>2</sup> ]
2,3,4 [51,76,102]	27 [12]	19 [123]

**ENGINEERING SPECIFICATION: ZURN Z1910-23**

Sani-Flor Receptor 8" x 8" x 6" [203mm x 203mm x 152mm] deep cast iron body and square, medium-duty grate with 7/16" [11mm] slotted openings, white acid resisting porcelain enamel interior and top, and black ground enamel exterior coating, complete with aluminum bucket.

**OPTIONS** (Check/specify appropriate options)

**PIPE SIZE**

- 3,4 [76,102]
- 2,3,4 [51,76,102]
- 2,3,4 [51,76,102]

(Specify size/type) **OUTLET**

- \_\_\_ IC Inside Caulk
- \_\_\_ NH No-Hub
- \_\_\_ NL Neo-Loc

**'E' BODY HT. DIMENSION**

Z	ZN
8-3/4 [222]	9-1/4 [235]
8-5/8 [219]	9-1/8 [232]
8 [203]	8-1/2 [216]

**PREFIXES**

- \_\_\_ Z Cast Iron Body with White A.R.E. Interior\*
- \_\_\_ ZN Cast Iron Body with White A.R.E. Interior, 8-9/16 [217] Square N.B. Frame and Full Grate with 5/16 [8] Square Openings (Add 1/2 [13] to 8 [203] and 'E' Dim.)

**SUFFIXES**

- |  |  |
|--|--|
| ___ -DX Dex-O-Tex Flange (ZN Only)                                       | ___ -8 Grate w/ 8-7/8 x 3-5/8 x 3-3/4 [225 x 92 x 95] High Oval Funnel |
| ___ -K Anchor Flange   | ___ -11 Vandal-Proof Secured Grate (ZN Only)                           |
| ___ -KC Anchor Flange with Seepage Holes and Clamp Collar                | ___ -15 Solid Loose Set Cover  |
| ___ -LD Less Bottom Dome Strainer  | ___ -19 Full Hinged Grate (ZN Only)                                    |
| ___ -P 1/2 [13] Trap Primer Connection (See Z1023)                       | ___ -31 Stainless Steel Mesh Liner for Bucket                          |
| ___ -TC Neo-Loc Test Cap Gasket (2,3,4 [51,76,102]NL Bottom Outlet Only) |  |
| ___ -1 Less Grate  |  |
| ___ -2 1/2 Grate   |  |
| ___ -3 3/4 Grate   |  |
| ___ -4 Full Grate with Square Center Opening                             |  |
| ___ -6 Grate w/ 6 [152] Dia. x 6 [152] High Funnel                       |  |

\* Regularly furnished unless otherwise specified.