

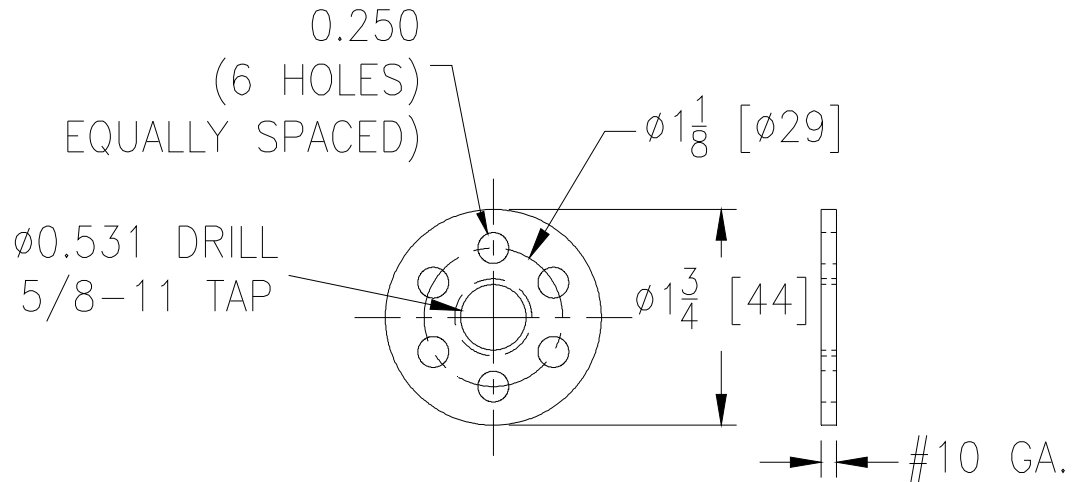

Z1210-74
FLUSH WALL ADJUSTMENT NUT FOR WALL HUNG TOILET CARRIER SYSTEM

SPECIFICATION SHEET
TAG _____

Dimensional Data (inches and [mm]) are Subject to Manufacturing Tolerances and Change Without Notice



ENGINEERING SPECIFICATION: ZURN Z1210-74

Ø1-3/4 O.D. adjustable washer with 5/8-11 threaded I.D. Designed to simplify the installation of wall hung toilet systems. Provides rigid, uniform support of the fixture to the finished wall.

REV. - DATE: 3/1/11 C.N. NO. 120954

DWG. NO. 301968 PRODUCT NO. Z1210-74

*REGULARLY FURNISHED UNLESS OTHERWISE SPECIFIED

ZURN INDUSTRIES, LLC ♦ SPECIFICATION DRAINAGE OPERATION ♦ 1801 Pittsburgh Ave. ♦ Erie, PA 16514

Phone: 814/455-0921 ♦ Fax: 814/454-7929 ♦ World Wide Web: www.zurn.com

In Canada: ZURN INDUSTRIES LIMITED ♦ 3544 Nashua Drive ♦ Mississauga, Ontario L4V1L2 ♦ Phone: 905/405-8272 Fax: 905/405-1292