



# Z100-202

SPECIFICATION SHEET

15 [381] DIAMETER MAIN ROOF DRAIN W/ PERFORATED  
BUCKET, PARTLY PERFORATED EXTENSION AND FLUSH GRATE

TAG \_\_\_\_\_

Dimensional Data (inches and [mm]) are Subject to Manufacturing Tolerances and Change Without Notice

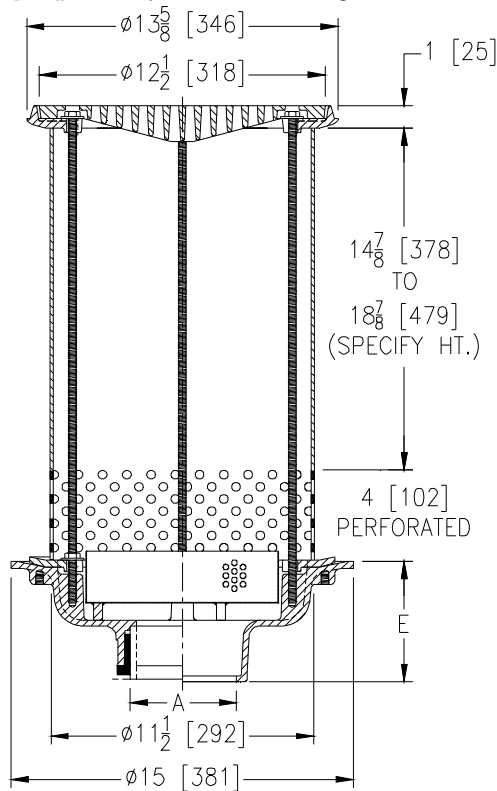

A Pipe Size	Approx. Wt. Lbs. [kg]	Grate Open Area Sq. In. [cm <sup>2</sup> ]
2,3,4 [51,76,102]	31 [14]	32 [206]
5,6 [127,152]	32 [15]	

**ENGINEERING SPECIFICATION: ZURN Z100-201**

15 [381] Diameter roof drain. Dura-Coated cast iron body with perforated bucket, flat clamping collar, extension with 4 [102] of perforations at the bottom, combination membrane flashing clamp/gravel guard and flush grate.

**OPTIONS** (Check/specify appropriate options)

**PIPE SIZE**

- 2 thru 6 [51 thru 152]
- 2 thru 6 [51 thru 152]
- 2 thru 6 [51 thru 152]
- 2,3,4 [51,76,102]
- 6 [152]

(Specify size/type) **OUTLET**

- \_\_\_\_\_ IC Inside Caulk
- \_\_\_\_\_ IP Threaded
- \_\_\_\_\_ NH No-Hub
- \_\_\_\_\_ NL Neo-Loc
- \_\_\_\_\_ NL Neo-Loc

**E BODY HT. DIM.**

- 5 1/4 [133]
- 3 3/4 [95]
- 5 1/4 [133]
- 4 9/16 [116]
- 5 7/16 [112]

**PREFIXES**

- \_\_\_\_\_ Z D.C.C.I. Body and Grate\*

**SUFFIXES**

- \_\_\_\_\_ -AC Angular Underdeck Clamp
- \_\_\_\_\_ -AR Acid Resistant Epoxy Coated
- \_\_\_\_\_ -C Underdeck Clamp
- \_\_\_\_\_ -DX Dex-o-tex Flange
- \_\_\_\_\_ -E Static Extension 1 [25] thru 4 [102] (Specify Ht.)
- \_\_\_\_\_ -G Galvanized Cast Iron
- \_\_\_\_\_ -R Roof Sump Receiver
- \_\_\_\_\_ -TC Neo-Loc Test Cap Gasket (2 - 4 [51 - 102] NL Bottom Outlet Only)
- \_\_\_\_\_ -VP Vandal-Proof Secured Top

REV.	DATE: 6/17/09	C.N. NO. 120072
DWG. NO. P-15720 PRODUCT NO. Z100-201		

\*REGULARLY FURNISHED UNLESS OTHERWISE SPECIFIED