



Z181-FS

6 [152] DIAMETER CORNICE DRAIN BOTTOM OUTLET
W/FLAT STRAINER

SPECIFICATION SHEET

TAG _____

Dimensional Data (inches and [mm]) are Subject to Manufacturing Tolerances and Change Without Notice

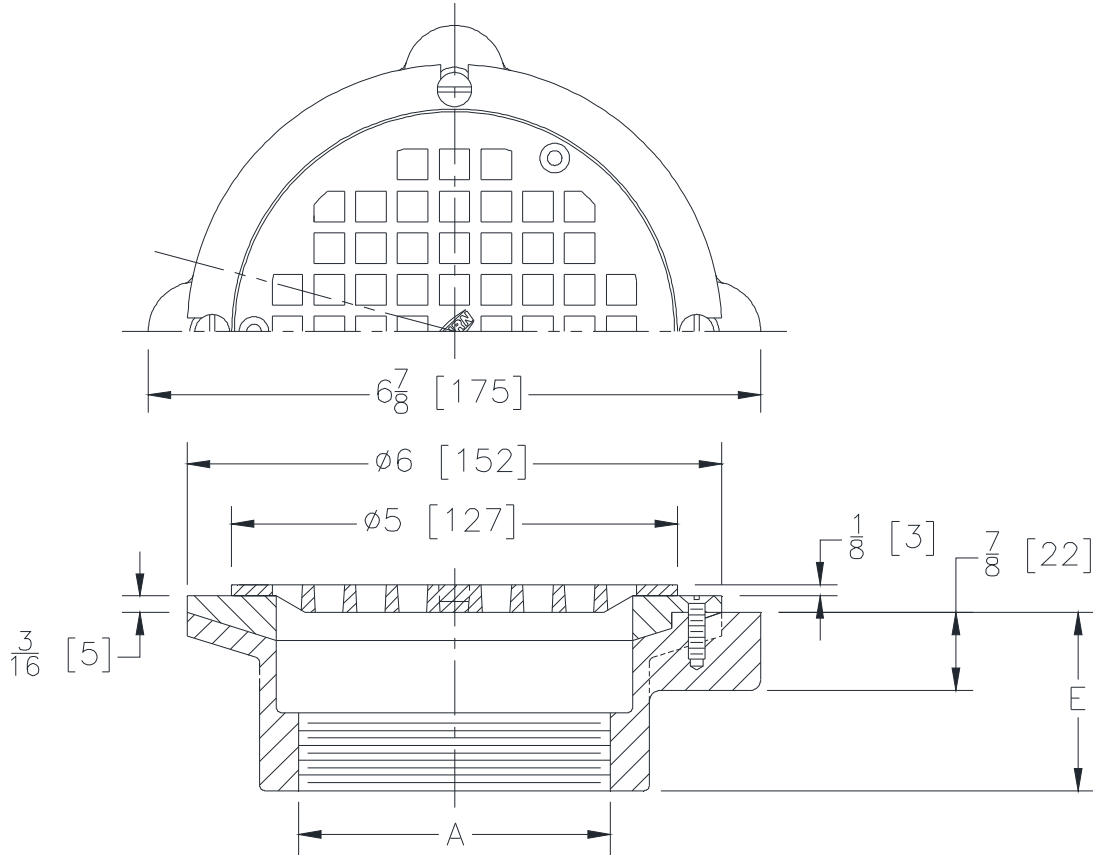

| A- Pipe Size In. [mm] | Approx. Wt. Lbs. [kg] | Grate Open Area Sq. In. [cm ²] |
|--------------------------|-----------------------------|---|
| 3 [76] | 6 [3] | 8 [203] |
| 4 [102] | 7 [4] | |

ENGINEERING SPECIFICATION: ZURN Z181-FS
6" [152mm] Diameter by 2" [51 mm] high cornice drain, Dura-Coated cast iron body, nickel bronze flat strainer and membrane flashing clamp.

OPTIONS (Check/specify appropriate options)

PIPE SIZE

3, 4 [76, 102]
3, 4 [76, 102]

(Specify size/type) **OUTLET**

_____ IP Threaded
_____ NH No-Hub (IP w/ Z1040)

'E' BODY HT. DIM

2 [51]
4-1/2 [114]

PREFIXES

_____ ZN D.C.C.I. Body with Polished Nickel Bronze Strainer*

SUFFIXES

_____ -C Underdeck Clamp
_____ -G Galvanized Cast Iron
_____ -R Roof Sump Receiver
_____ -VP Vandal Proof Secured Top

* Regularly furnished unless otherwise specified.