



Z-1019-F6

FUNNEL DRAIN WITH "P" TRAP

SPECIFICATION SHEET

TAG _____

Dimensional Data (inches and [mm]) are Subject to Manufacturing Tolerances and Change Without Notice

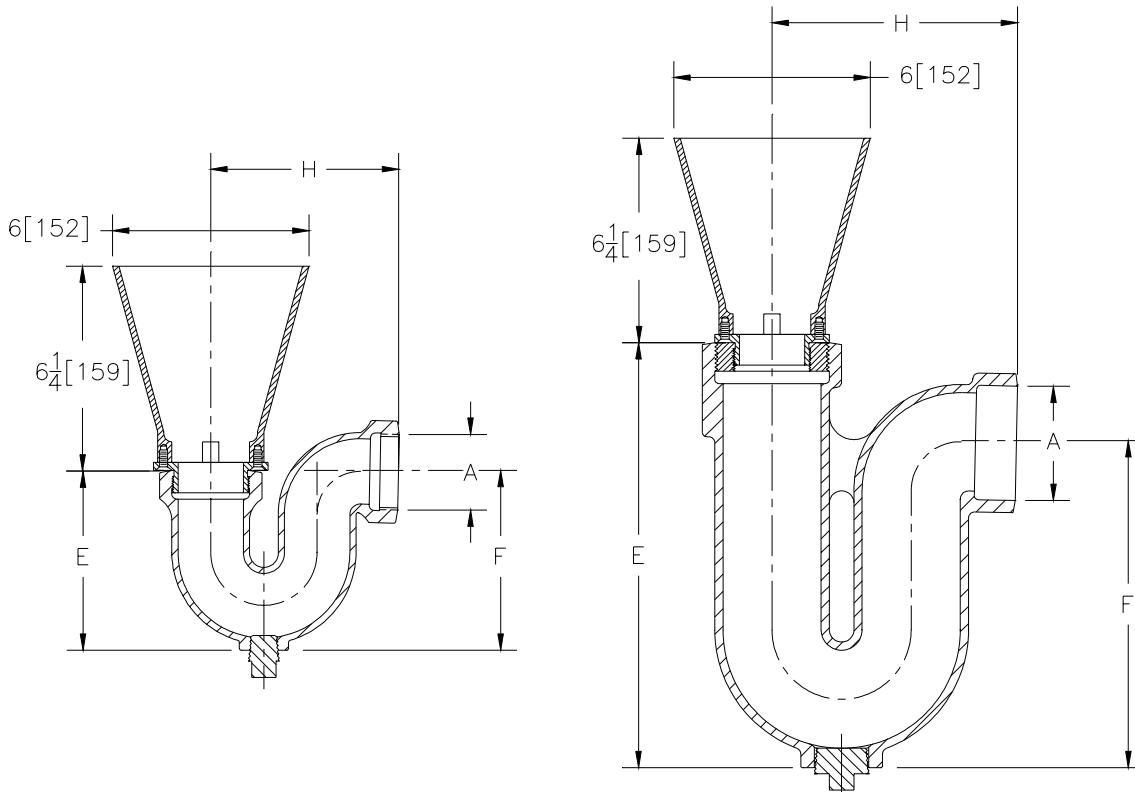

Dimensions In Inches				Approx. Wt. Lbs. [kg]
A Pipe Size	E	F	H	
2 [50]	4 1/4 [108]	5 1/2 [140]	5 3/4 [146]	10 [5]
3 [75]	13 [330]	10 [254]	7 1/2 [190]	19 [9]

ENGINEERING SPECIFICATION: ZURN Z-1019-F6 Dura-Coated cast iron combination funnel and trap drain, complete with bronze bottom cleanout plug.

CONNECTIONS (Check/specify appropriate options)

PIPE SIZE _____ (Specify size/type) **CONNECTION** _____

2, 3 [50, 75] _____ IP Threaded

PREFIXES

- _____ Z- D.C.C.I. Body and Top*
- _____ ZAB- Bronze Body with Polished Bronze Top
- _____ ZABN Bronze Body with Polished Nickel Bronze Top

SUFFIXES

- _____ -AR Acid Resisting Epoxy Coated Finish (Z only)
- _____ -DS Dome Strainer
- _____ -G Galvanized Cast Iron

*REGULARLY FURNISHED UNLESS OTHERWISE SPECIFIED

REV.	DATE: 2/20/97	C.N. NO. 77042
DWG. NO. 61450	PRODUCT NO. Z-1019-F6	